

# Battery vision three backup booster

**Quickstart Guide**

**Schnellstartanleitung**

**Guide de démarrage rapide**

**Guida rapida**

**Snelstartgids**

Battery vision three backup booster is a three-phase automatic switching device available as a supplementary product for installation with Inverter vision three. It enhances the three-phase backup functionality of an Inverter vision three by allowing the backup circuits to not be powered through the inverter when a mains voltage is present.

Battery vision three backup booster ist ein Ergänzungsprodukt zum Inverter vision three und erleichtert die Integration des Netzersatzstrombetriebes in die Gebäudeinstallation.

**IMPORTANT:** Check whether these instructions are up-to-date. You can find the current version and all language variants under this QR code:



**WICHTIG:** Prüfen Sie, ob diese Anleitung aktuell ist. Die aktuelle Version und alle Sprachvarianten finden Sie unter diesem QR-Code:

For detailed Installation and Operating Instructions scan the QR code below.



Für die ausführliche Installations- und Bedienungsanleitung scannen Sie den folgenden QR code.



Pour des instructions d'installation et d'utilisation détaillées, scannez le code QR ci-dessous.



Per istruzioni dettagliate sull'installazione e l'uso, scansionare il codice QR qui sotto.



Scan de QR-code hieronder voor gedetailleerde installatie en gebruiksinstructies.



# SYSTEM DESIGN

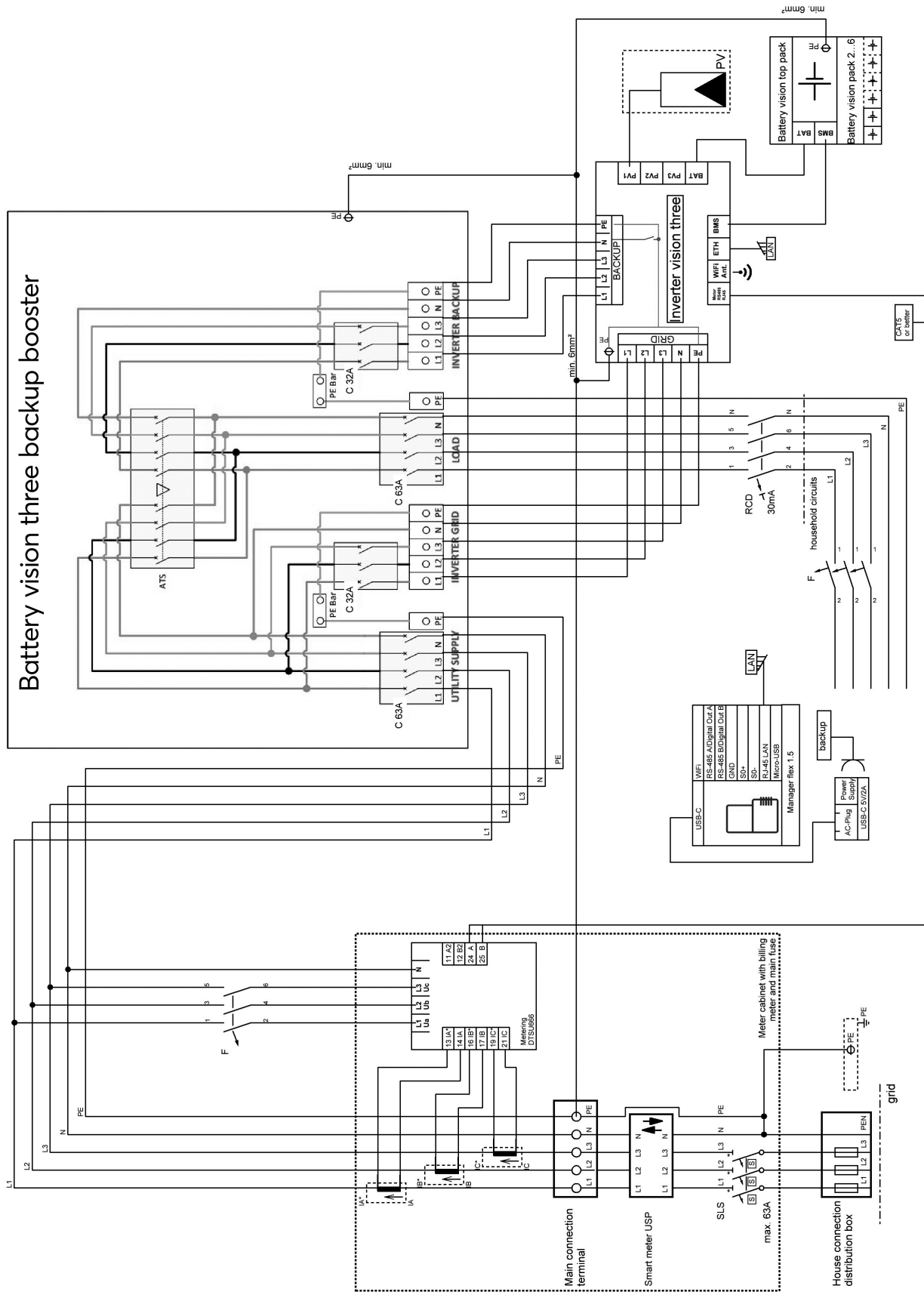

## DEVICE DESIGN AND PACKING LISTS

### Battery vision three backup booster

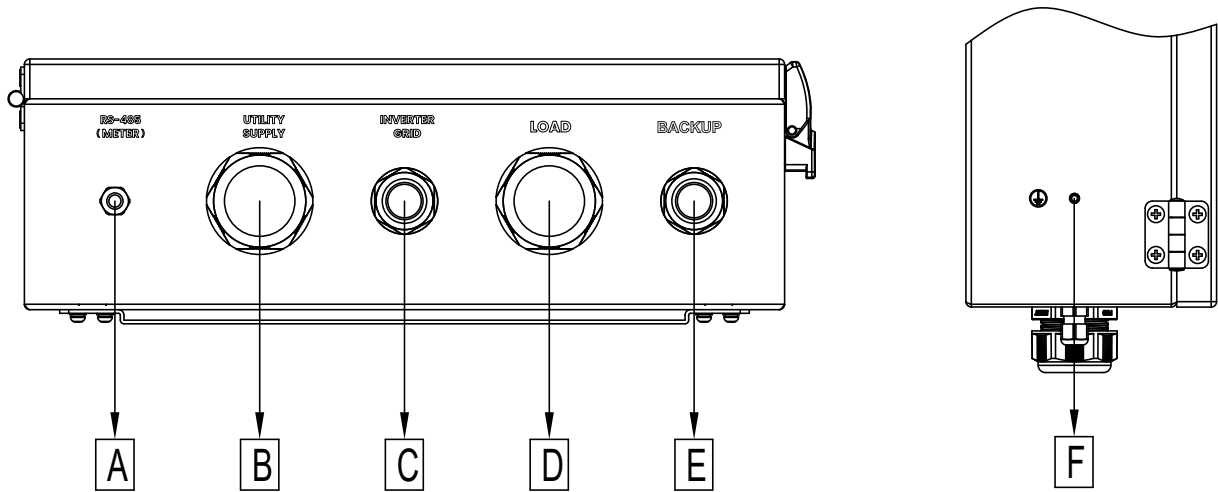

A RS485 CONNECTION  
(METER) OPTIONAL\*  
B GRID CONNECTION

C INVERTER GRID  
CONNECTION  
D HOUSE CONNECTION

E INVERTER BACKUP  
CONNECTION  
F GROUNDING

\* The A port is not used, the meter (chint meter DTSU 666) is connected to the inverter vision.

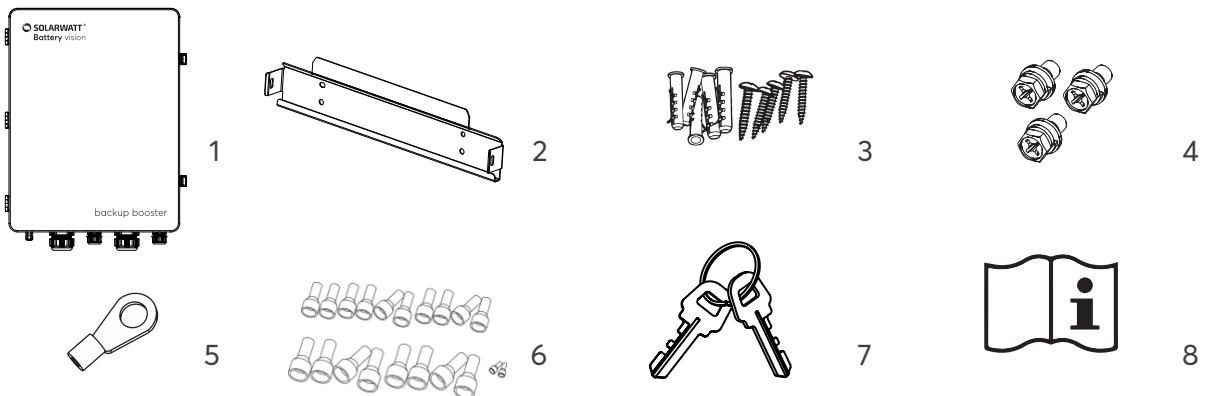

- 1 Battery vision three backup booster
- 2 Fixing bracket
- 3 Screws and dowels  
4x for wall fixing
- 4 Screws  
2x for fixing backup booster to wall bracket  
1x Earthing screw
- 5 Cable lug for grounding cable
- 6 End splices (20x)

- 7 Keys
- 8 Safety Instructions  
Quickstart Guide

Settings and Functions

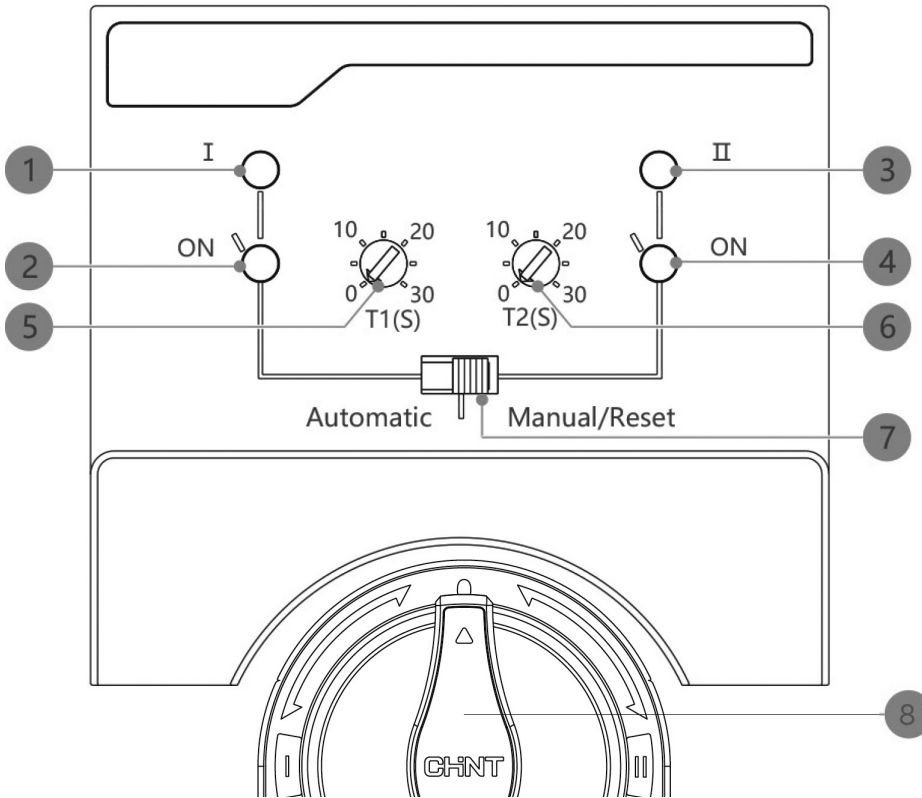

- 1 Indicator for **mains voltage**  
LED lights up red when **voltage from the public grid is present**
- 2 Indicator for the power supply **from the public grid**  
LED lights up green when the mains-side power supply is switched on  
**Switch position to the left**
- 3 Indicator for **voltage in the backup path**  
LED lights up red when **voltage is present on the backup path**
- 4 Indicator for **mains backup power supply**  
LED lights up green when the **mains backup power supply is switched on**  
**Switch position to the right**
- 5 Setting the switchover delay time for switching from mains-coupled operation to mains backup operation
- 6 Setting the return delay time for switching from mains backup power supply operation to grid-connected operation
- 7 Automatic/manual switchover
- 8 Changeover switch for switching between grid-connected operation and mains backup power supply

## DIMENSIONS AND INSTALLATION SPACE

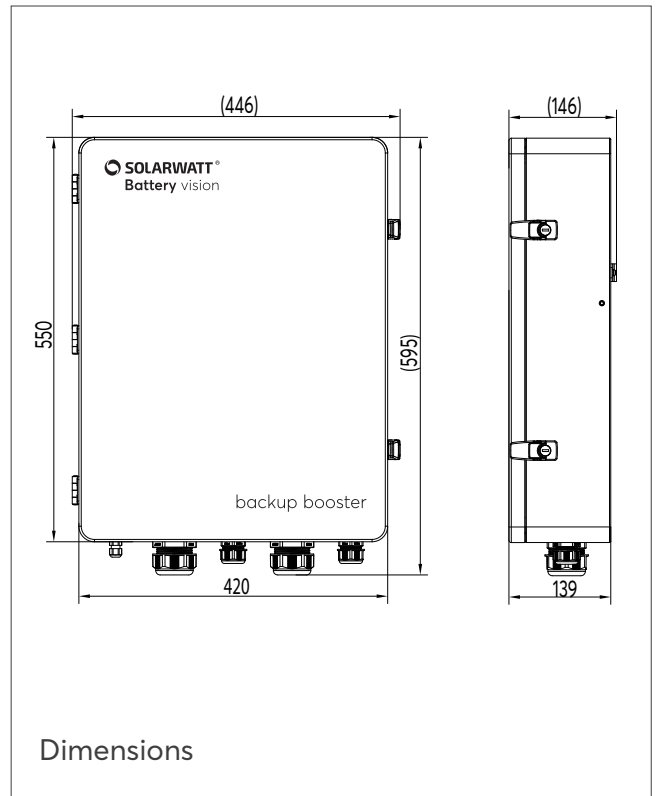
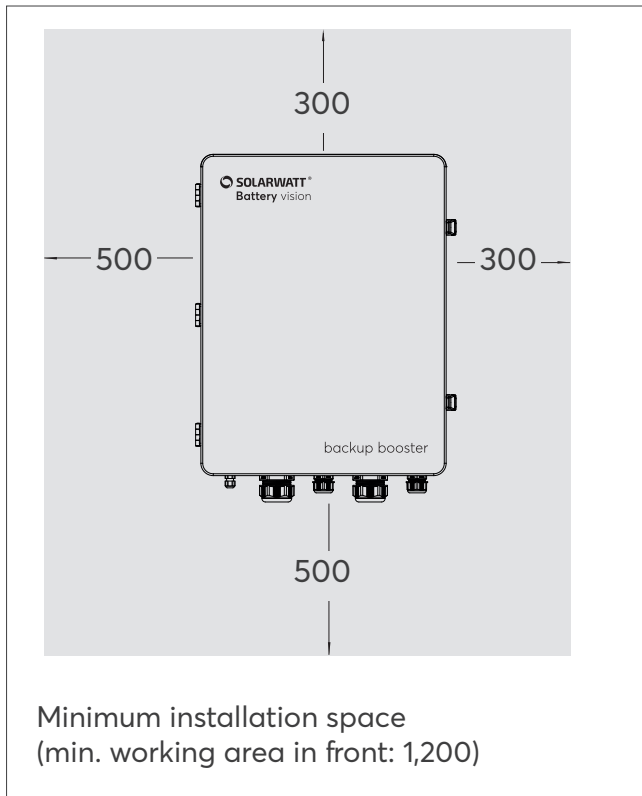

## ASSEMBLY

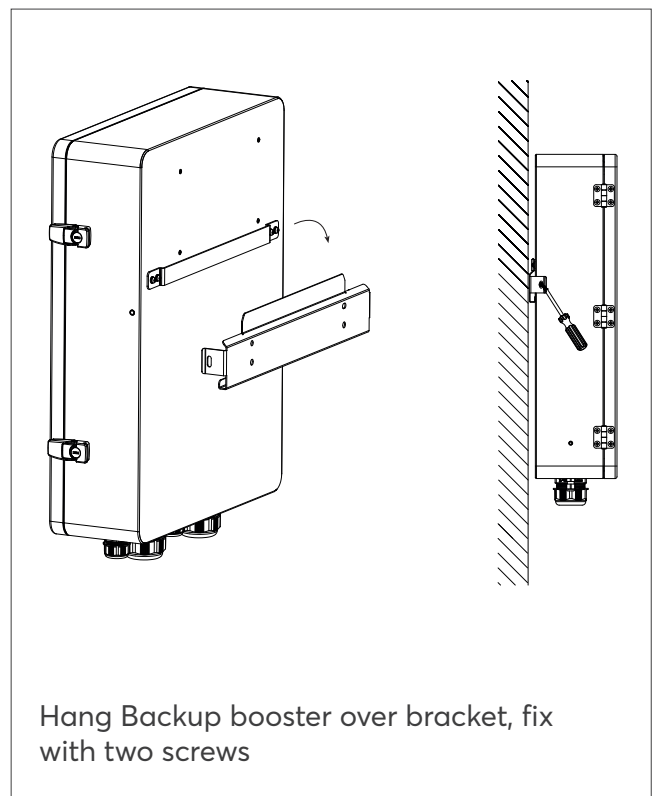
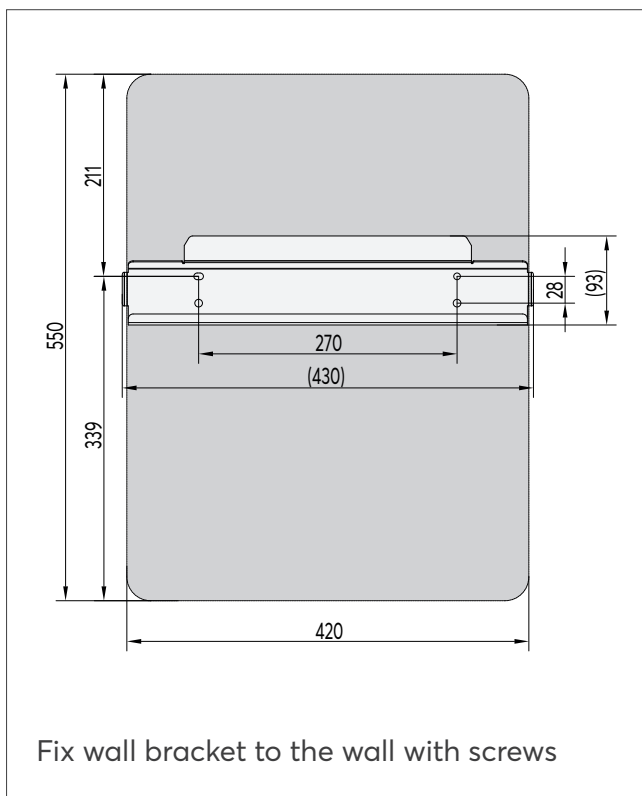

# INSTALLATION BETWEEN HOME DISTRIBUTION AND INVERTER VISION

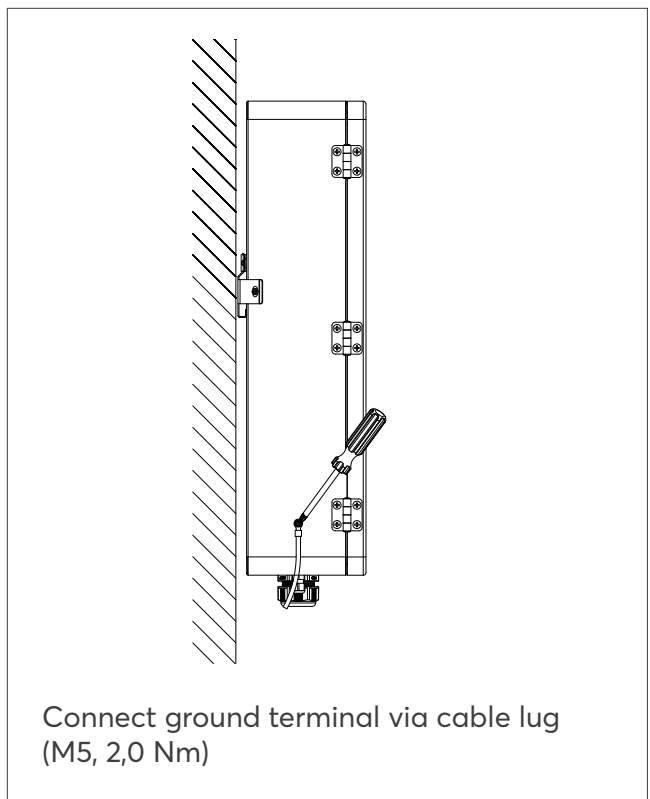
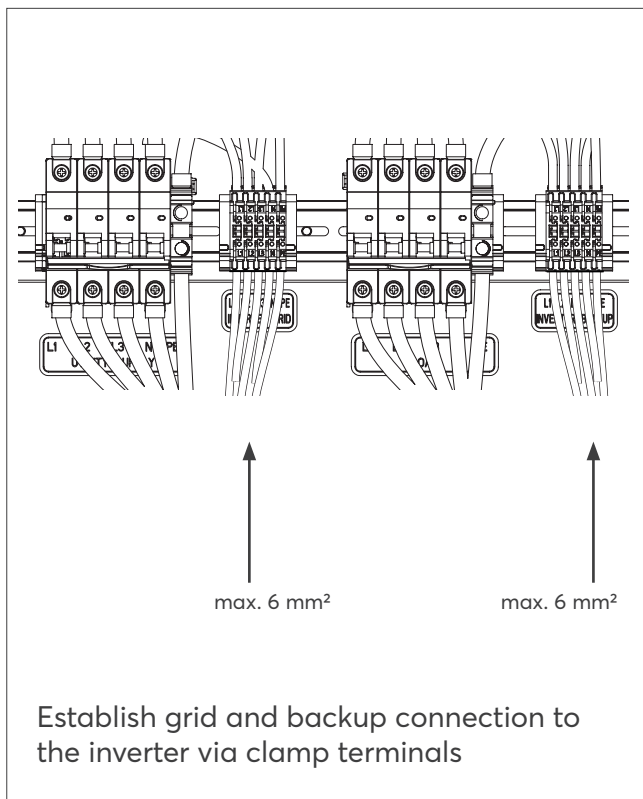
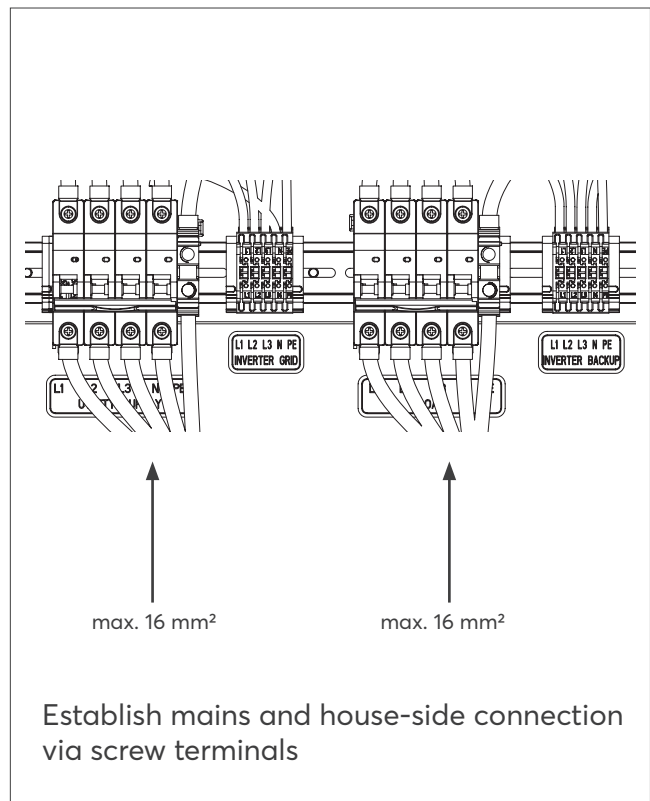
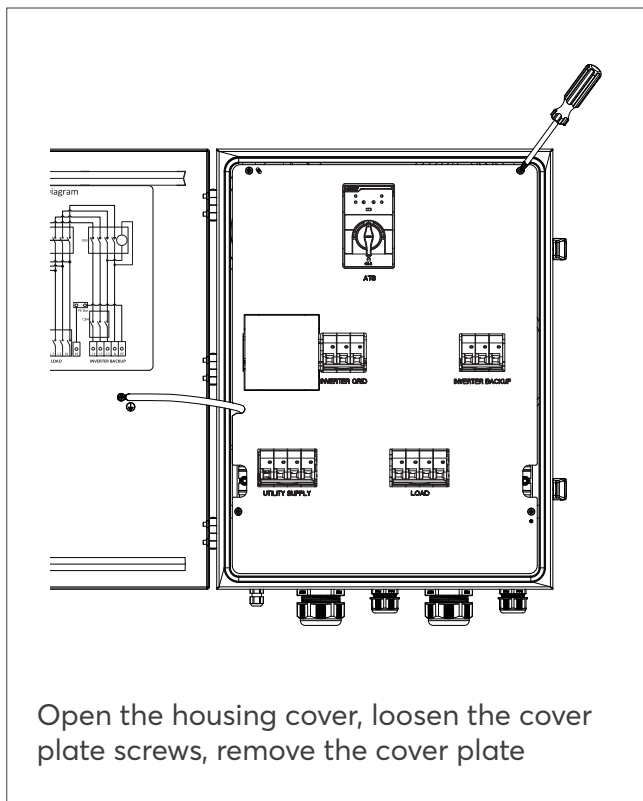

## INSTALLATION BETWEEN HOME DISTRIBUTION AND INVERTER VISION

- Check that the device is installed safely and reliably.
- Check that the grounding cable is connected correctly, securely and reliably.
- Check that all cables are connected correctly, securely and reliably and that the phase sequence is correct.

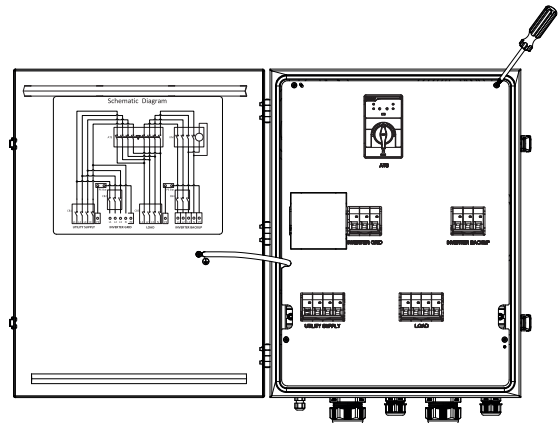

Close the cover plate

## SYSTEMSTART

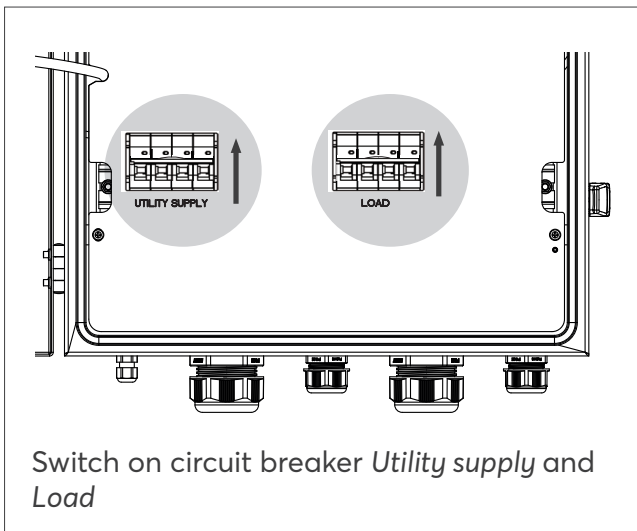

Switch on circuit breaker *Utility supply* and *Load*

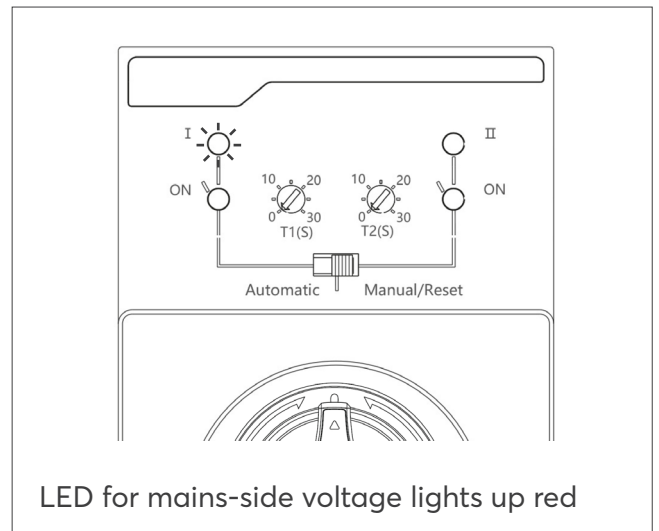

LED for mains-side voltage lights up red

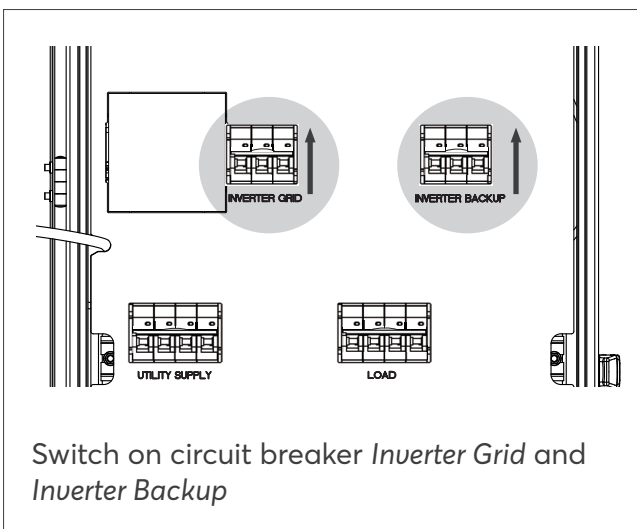

Switch on circuit breaker *Inverter Grid* and *Inverter Backup*



Start Inverter vision three and Battery vision according to the online manual

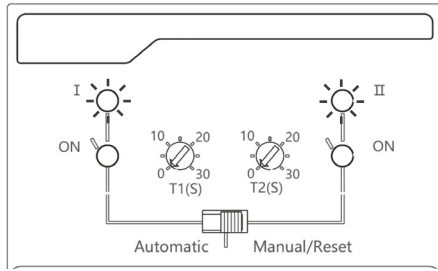

When the inverter starts up, the LED for voltage on the backup path lights up red.

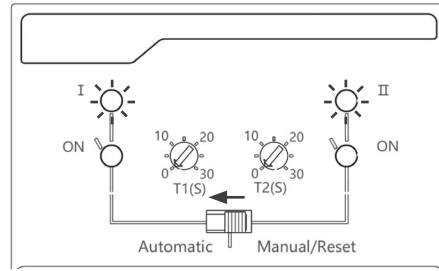

Change the slide switch from 'Manual' to 'Automatic'

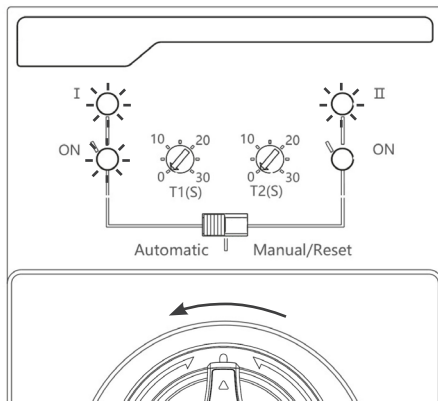

Switch turns to the left, LED for power supply from the public grid lights up green

# TEST MAINS BACKUP OPERATION

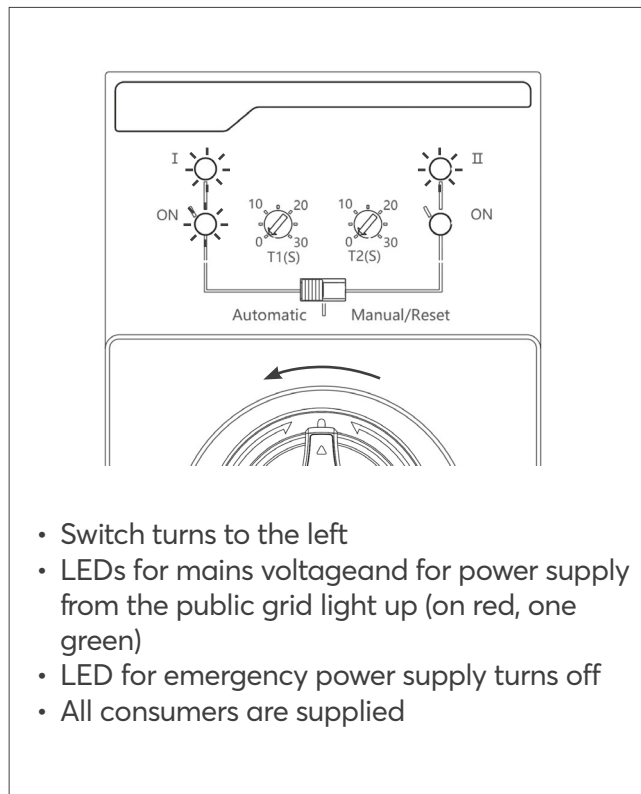
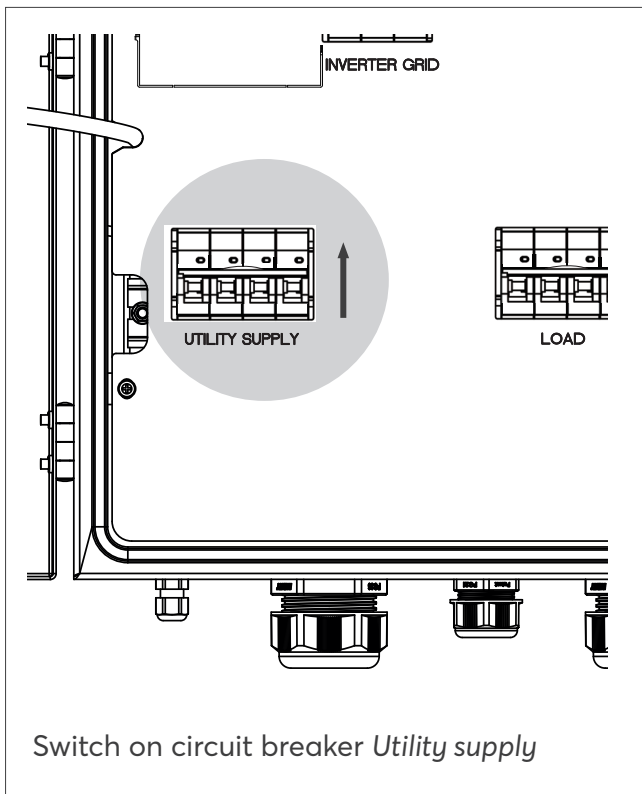
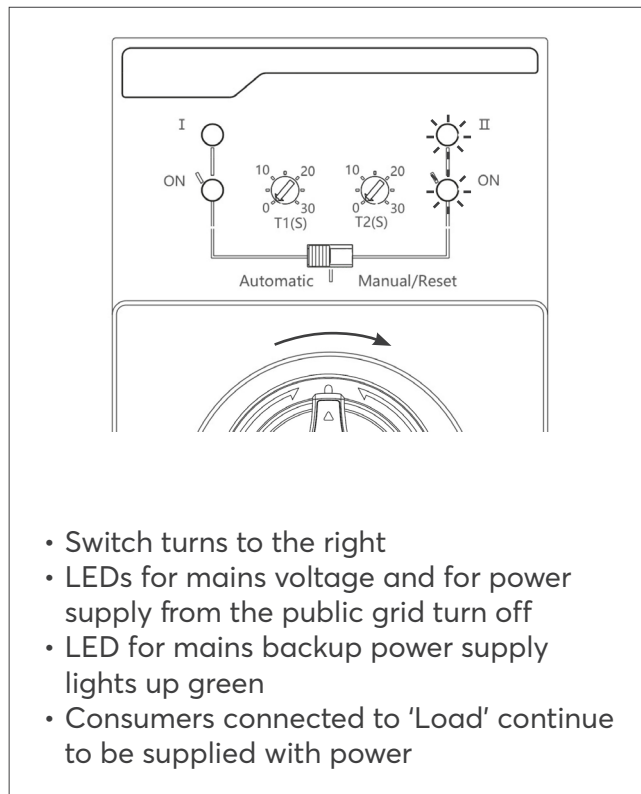
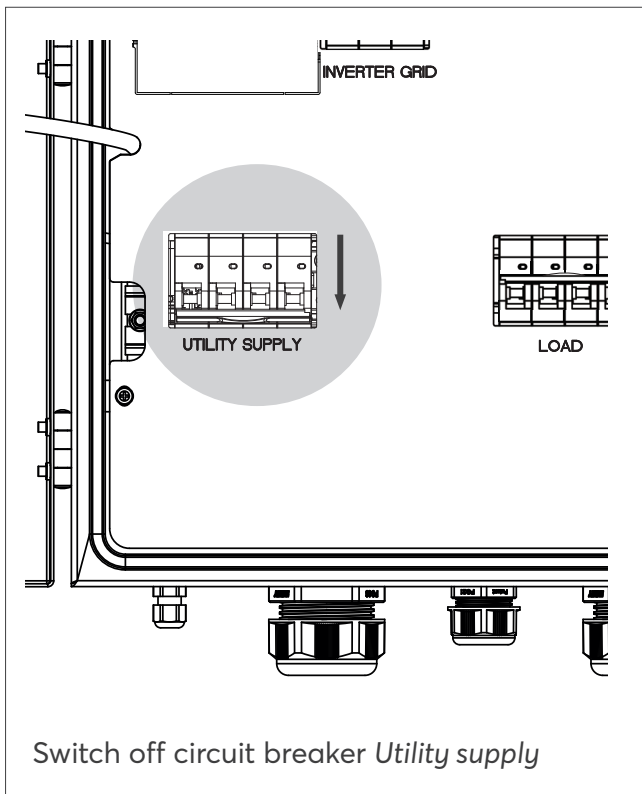



Disposal as electronic waste

## AUFBAU UND LIEFERUMFANG

### Battery vision three backup booster

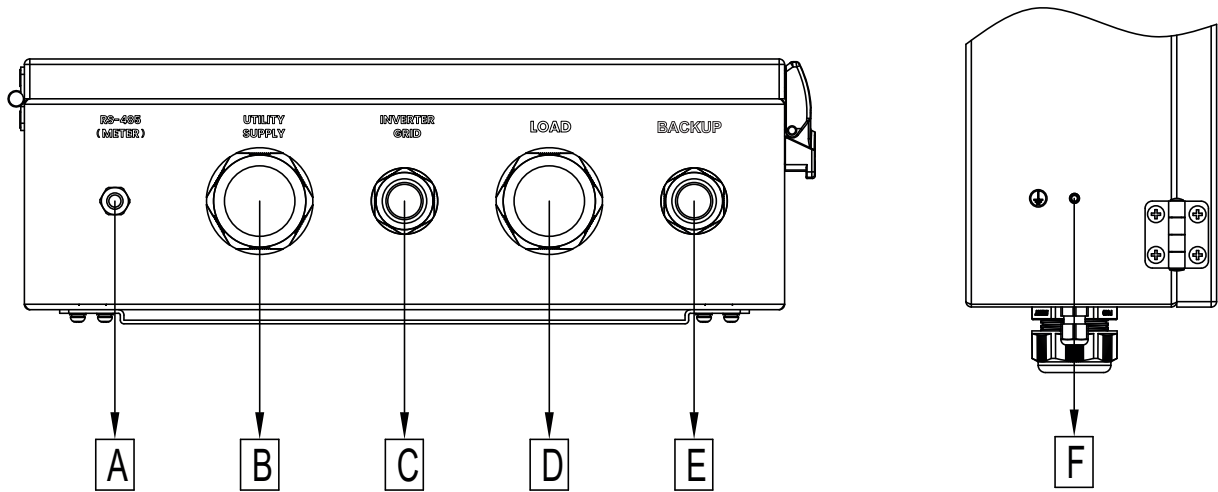

A ANSCHLUSS RS485  
(ZÄHLER) OPTIONAL\*  
B ANSCHLUSS NETZ

C ANSCHLUSS GRID DES  
WECHSELRICHTERS  
D ANSCHLUSS HAUS

E ANSCHLUSS BACKUP  
DES WECHSELRICHTERS  
F ERDUNG

\* der Eingangs A (Zähler) wird nicht belegt, der Zähler (Chint Meter DTSU 666) wird am Inverter vision angeschlossen

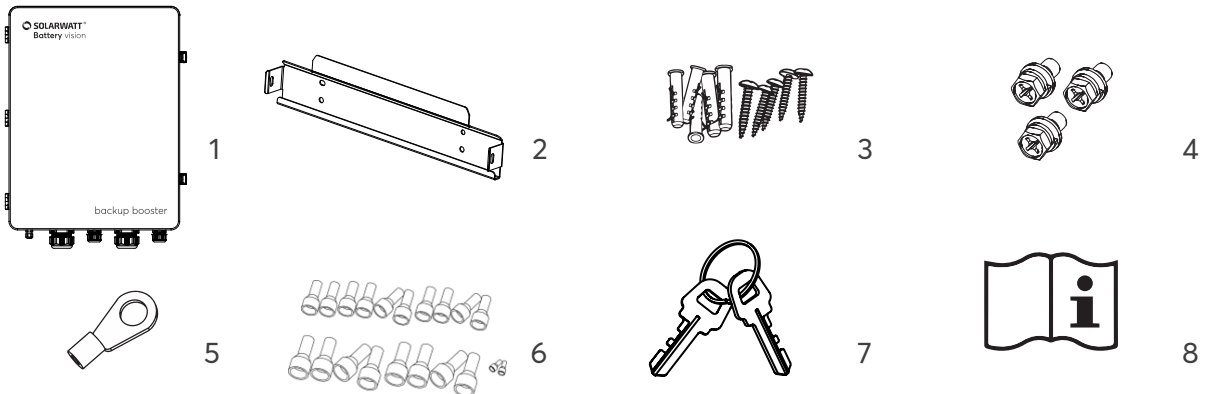

1 Battery vision three backup booster  
2 Wandhalter  
3 Schrauben und Dübel (4x)  
4x für Wandbefestigung  
4 Schrauben  
2x für Befestigung backup booster an Wand-  
halter, 1x Erdung

5 Kabelschuh für  
Erdungskabel  
6 Aderendhülsen (20x)

7 Schlüssel  
8 Schnellstartanleitung  
Sicherheitshinweise

### Einstellungen und Funktionen

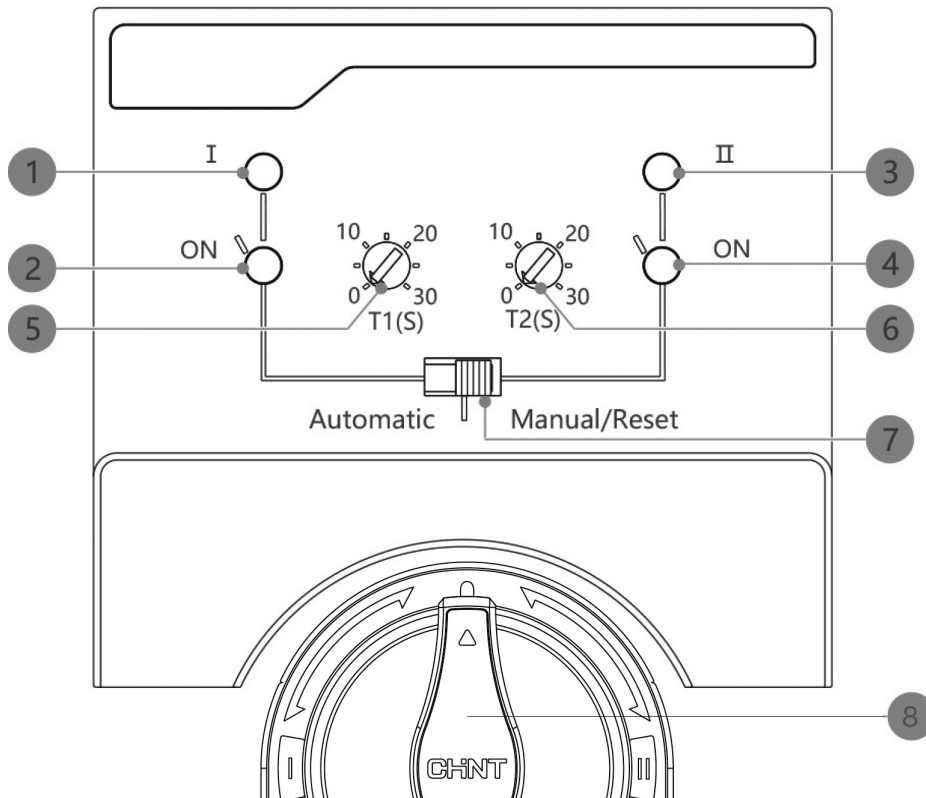

- 1 Anzeige für **netzseitige Spannung**  
LED leuchtet rot, wenn **Spannung vom öffentlichen Netz anliegt**
- 2 Anzeige für die **Stromversorgung aus dem öffentlichen Netz**  
LED leuchtet grün, wenn die **netzseitige Stromversorgung zugeschaltet** ist  
**Schalterstellung nach links**
- 3 Anzeige für **Spannung im backup-Pfad**  
LED leuchtet rot, wenn **Spannung am backup Pfad anliegt**
- 4 Anzeige für **Netzersatzstromversorgung**  
LED leuchtet grün, wenn die **Netzersatzstromversorgung zugeschaltet** ist  
**Schalterstellung nach rechts**
- 5 Einstellung der Umschaltverzögerungszeit für das Umschalten vom netzgekoppelten Betrieb auf Netzersatzbetrieb
- 6 Einstellung der Rücklaufverzögerungszeit für das Umschalten von Netzersatzbetrieb in den netzgekoppelten Betrieb
- 7 Automatisches/manuelles Umschalten
- 8 Umschalter zwischen Stromversorgung aus dem öffentlichen Netz und Netzersatzbetrieb

## MONTAGEABSTAND UND ABMESSUNGEN

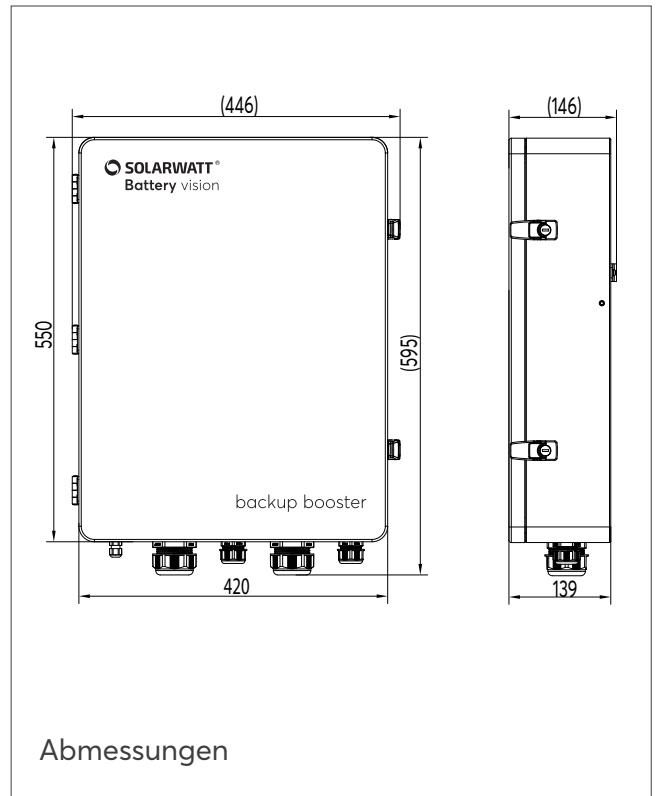
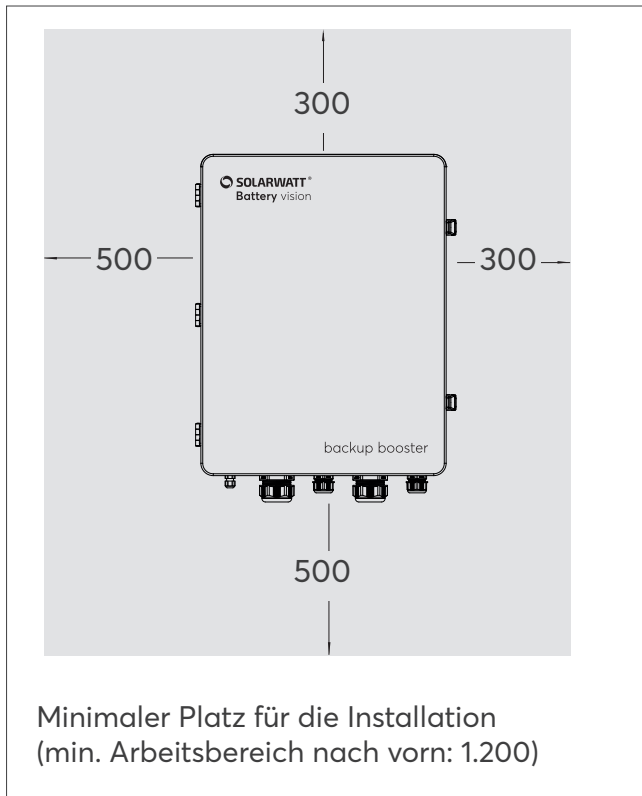

## MONTAGE

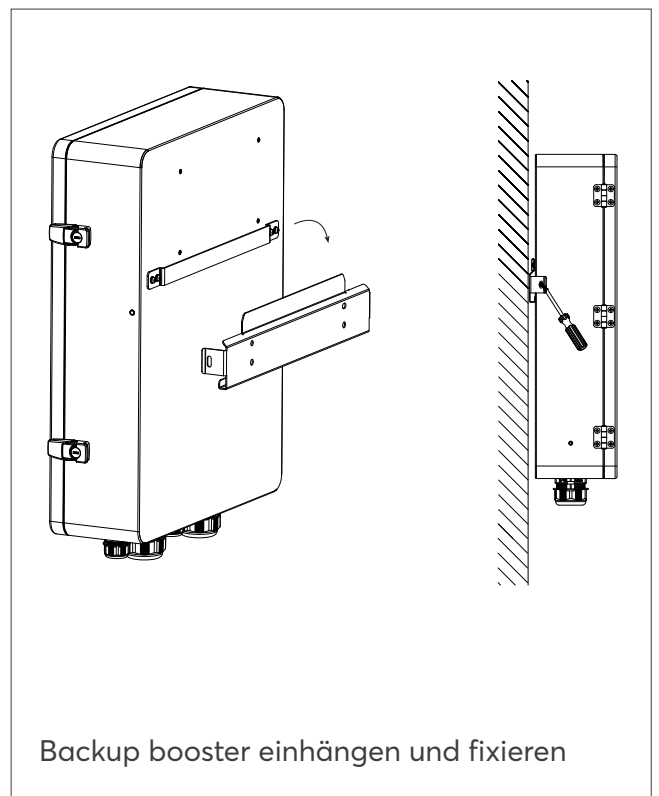
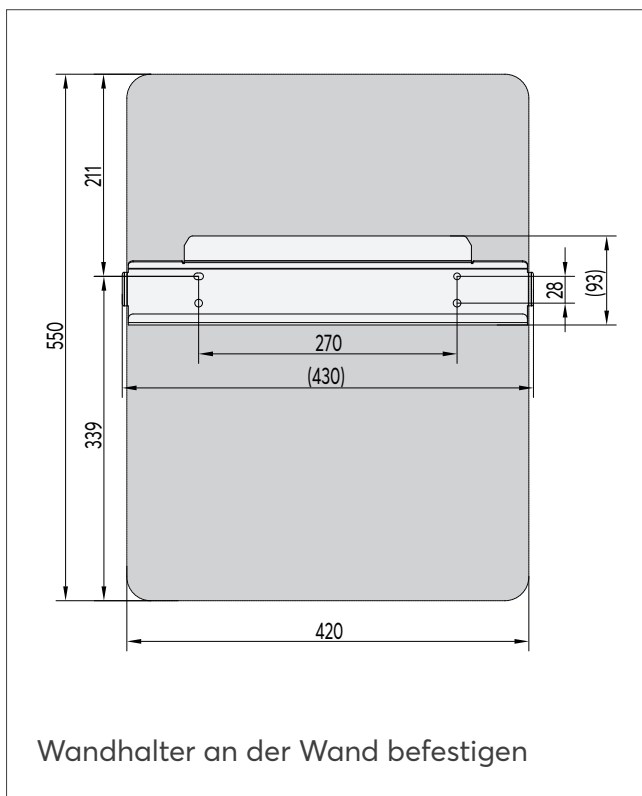

# EINBINDUNG ZWISCHEN HAUSVERTEILUNG UND INVERTER VISION

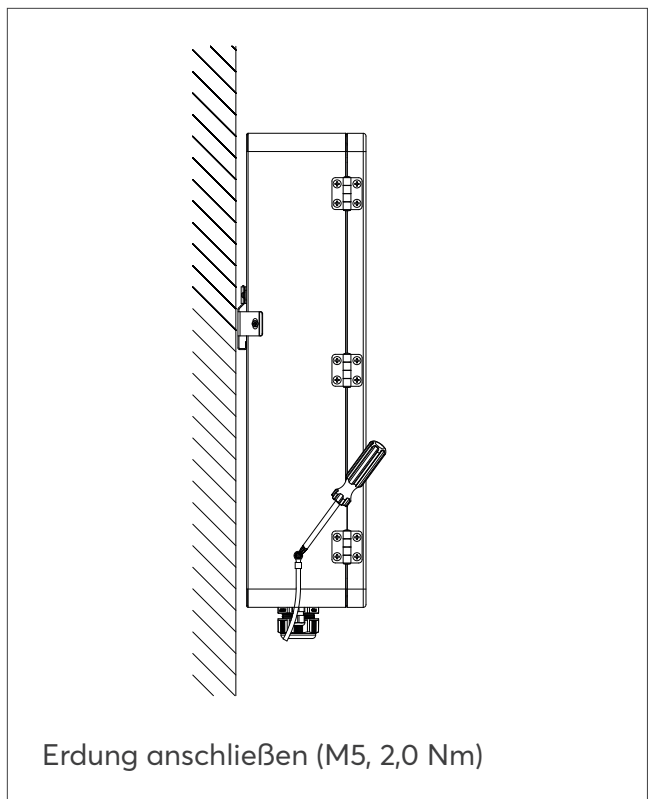
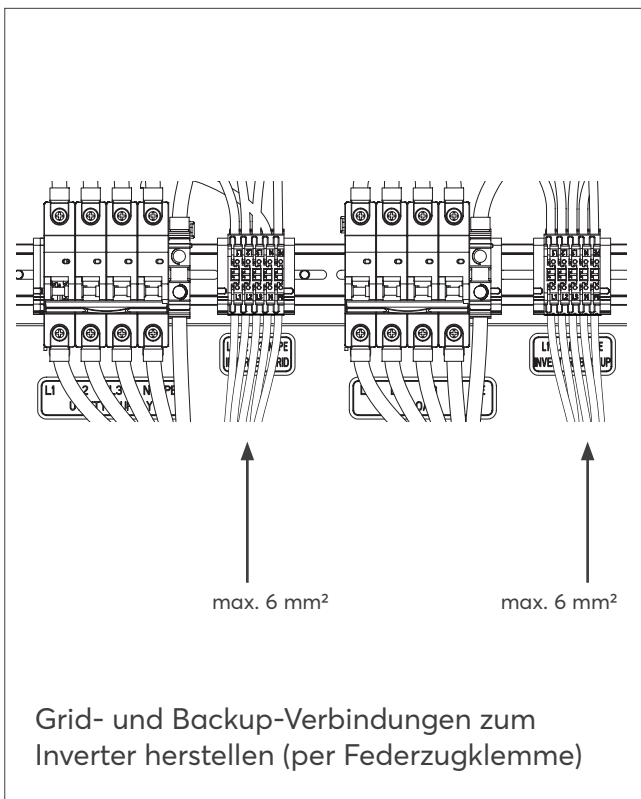
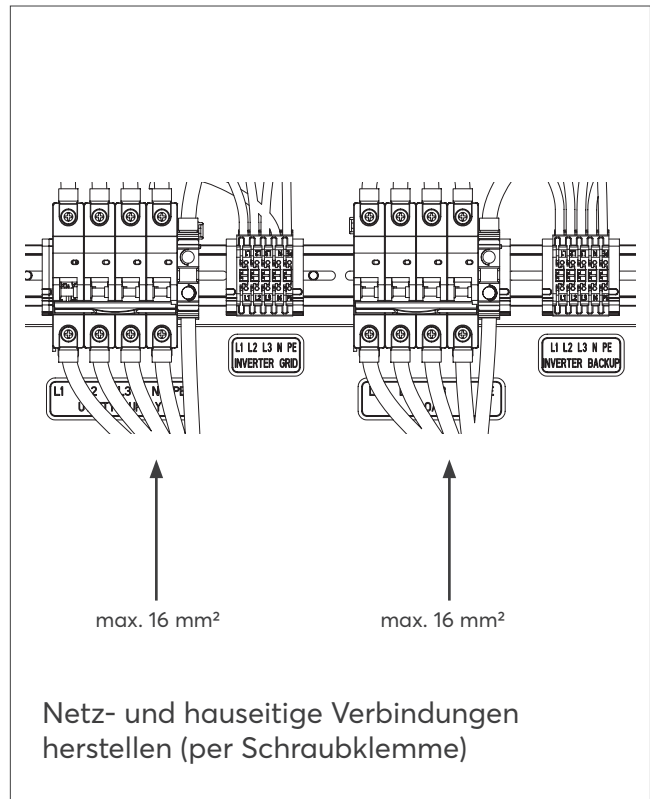
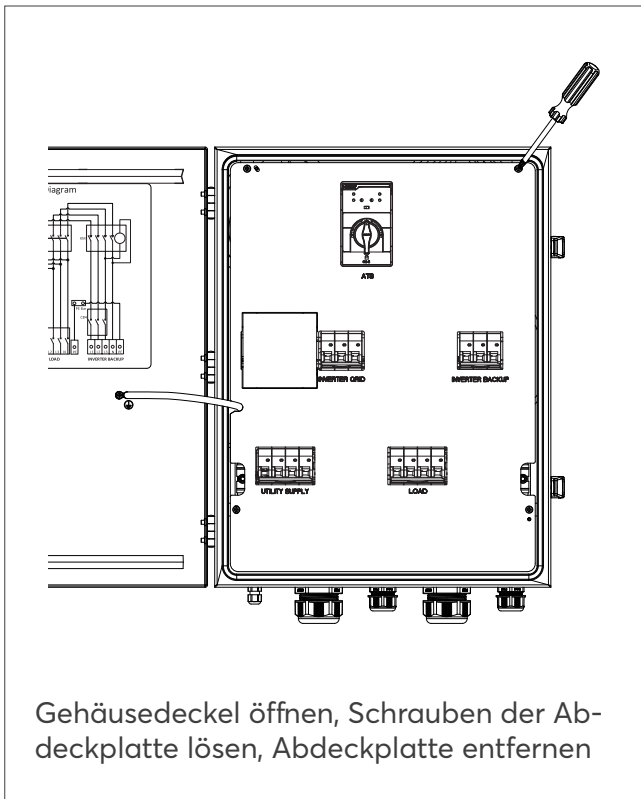

- Prüfen, dass das Gerät sicher und zuverlässig installiert ist.
- Prüfen, ob das Erdungskabel richtig, fest und zuverlässig angeschlossen ist.
- Prüfen, ob alle Kabel richtig, fest und zuverlässig angeschlossen sind und die Phasenfolge korrekt ist.

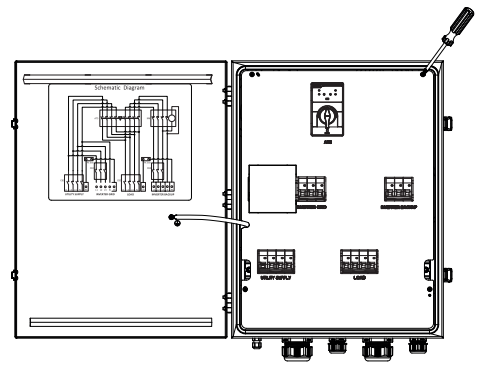

Abdeckplatte schließen

## SYSTEMSTART

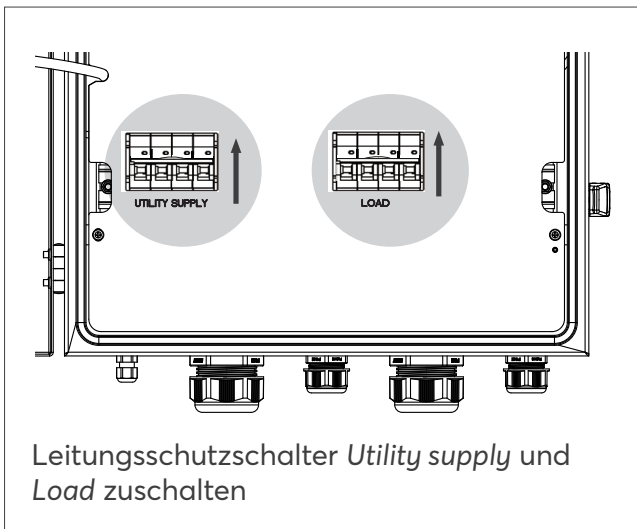

Leitungsschutzschalter *Utility supply* und *Load* zuschalten

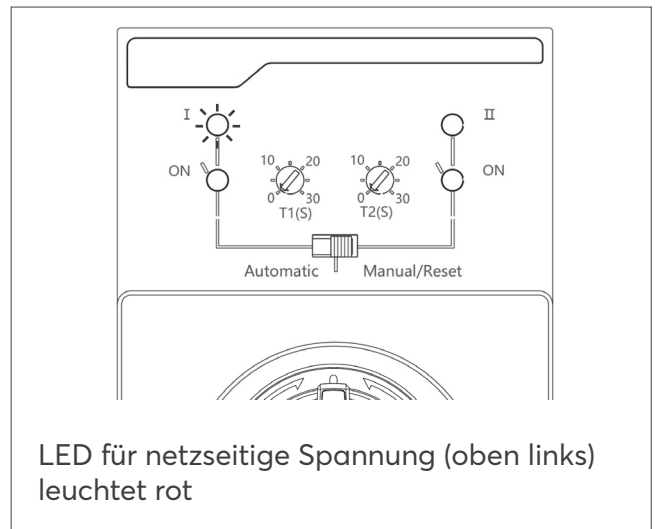

LED für netzseitige Spannung (oben links) leuchtet rot

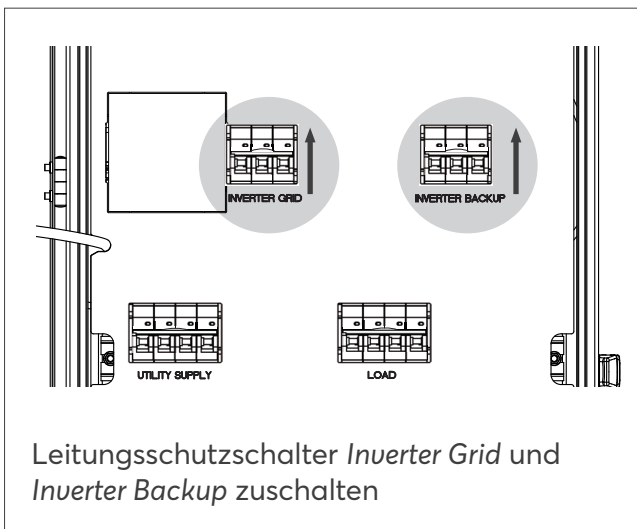

Leitungsschutzschalter *Inverter Grid* und *Inverter Backup* zuschalten



Inverter vision three und Battery vision gemäß Onlinehandbuch starten

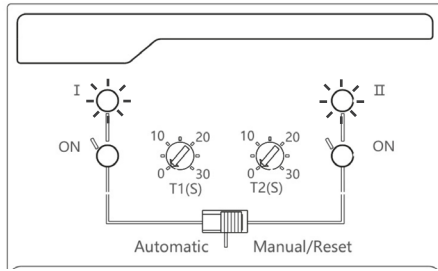

Wenn der Wechselrichter startet, leuchtet die LED für Spannung am backup Pfad (oben rechts) rot.

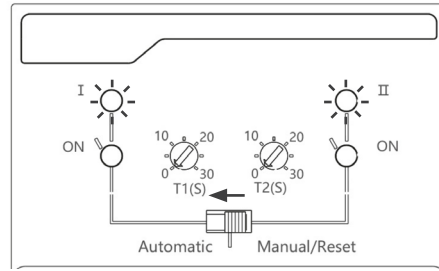

Schiebeschalter von „Manual“ auf „Automatic“ umstellen

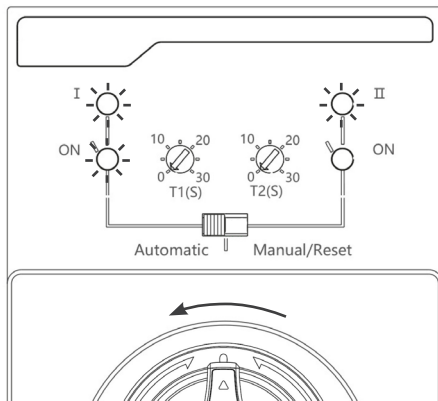

Umschalter dreht nach links, LED für Stromversorgung aus dem öffentlichen Netz (unten links) leuchtet grün

## TEST NETZERSATZBETRIEB

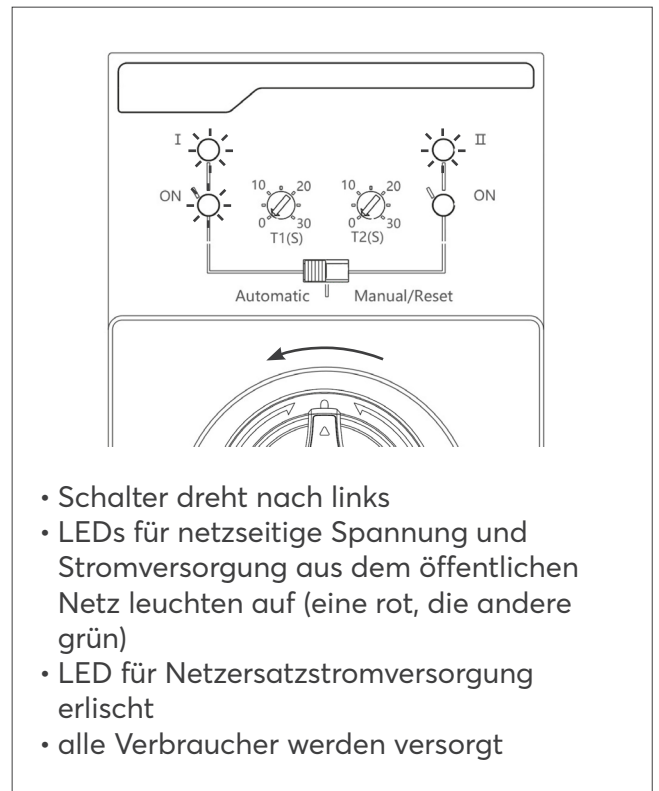
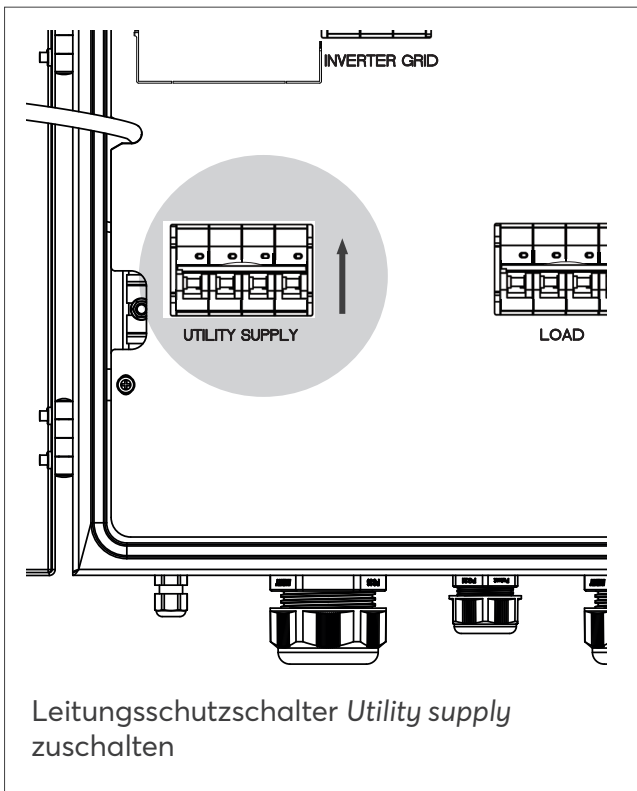
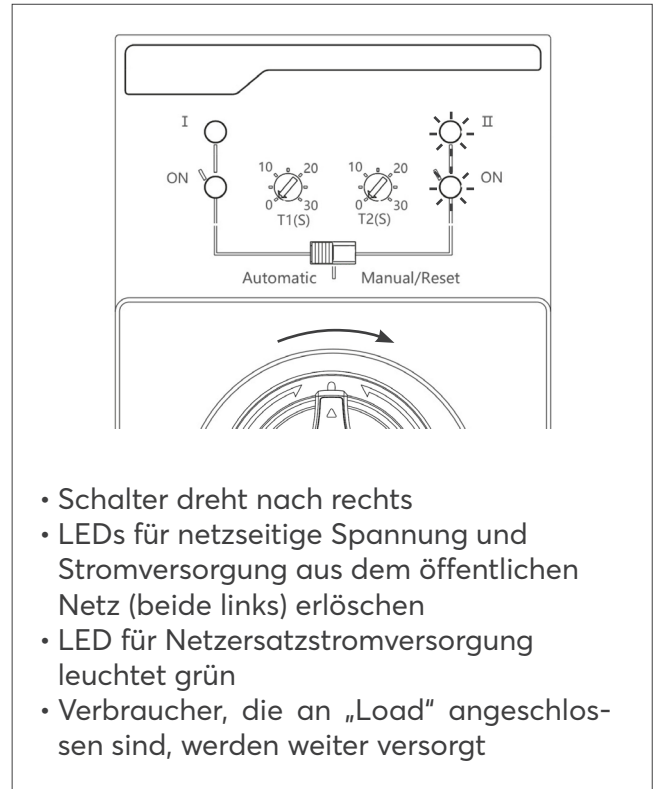
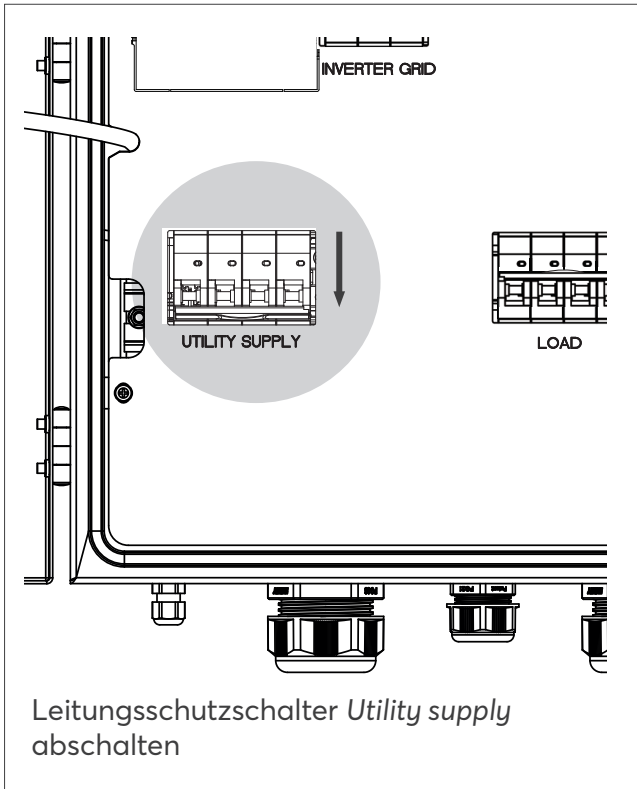



Entsorgung als Elektroschrott

## COMPOSITION DU SYSTÈME ET CONTENU DE LA LIVRAISON

### Battery vision three backup booster

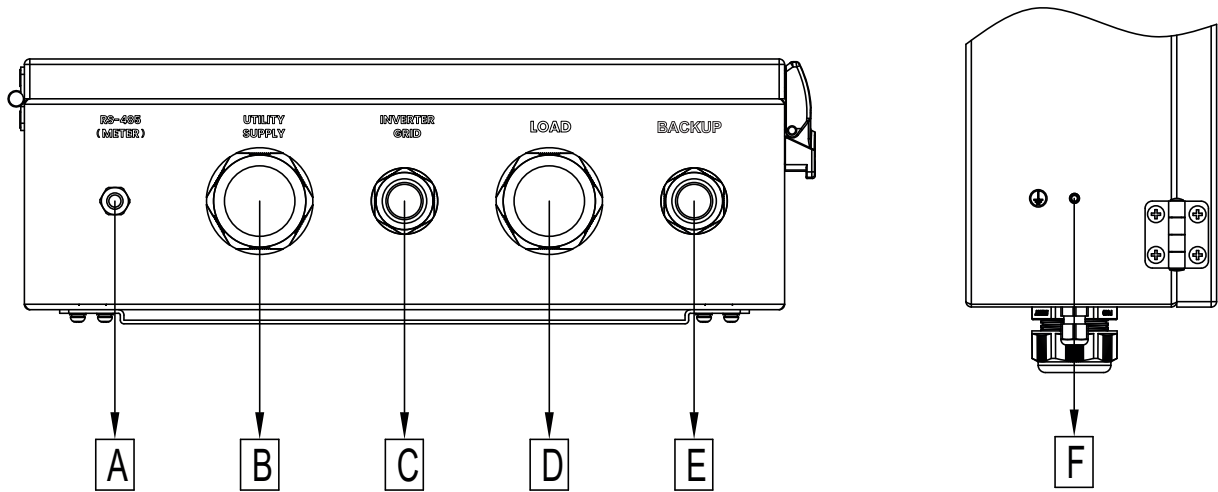

- |  |                                   |                                     |
|--|-----------------------------------|-------------------------------------|
| A RACCORDEMENT RS485 (COMPTEUR) EN OPTION* | C RACCORDEMENT GRID DE L'ONDULEUR | E RACCORDEMENT BACKUP DE L'ONDULEUR |
| B RACCORDEMENT AU RÉSEAU                   | D RACCORDEMENT MAISON             | F MISE À LA TERRE                   |

\* L'entrée A (compteur) n'est pas utilisée, le compteur (Chint Meter DTSU 666) est raccordé à l'Inverter vision.

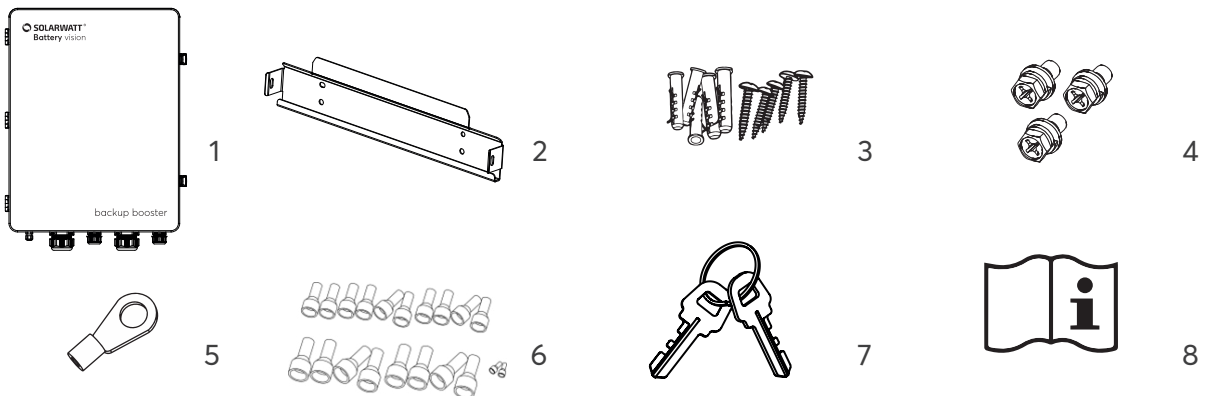

- |   |                                       |                             |
|---|---------------------------------------|-----------------------------|
| 1 Battery vision three backup booster   | 5 Cosse pour câble de mise à la terre | 7 Clé                       |
| 2 Support mural   | 6 Embouts de câble (20x)              | 8 Guide de démarrage rapide |
| 3 Vis et chevilles<br>4x pour la fixation murale                                    |                                       | Consignes de sécurité       |
| 4 Vis<br>2x pour la fixation du backup booster au support mural, 1x mise à la terre |                                       |                             |

## COMPOSITION DU SYSTÈME ET CONTENU DE LA LIVRAISON

### Paramètres et fonctions

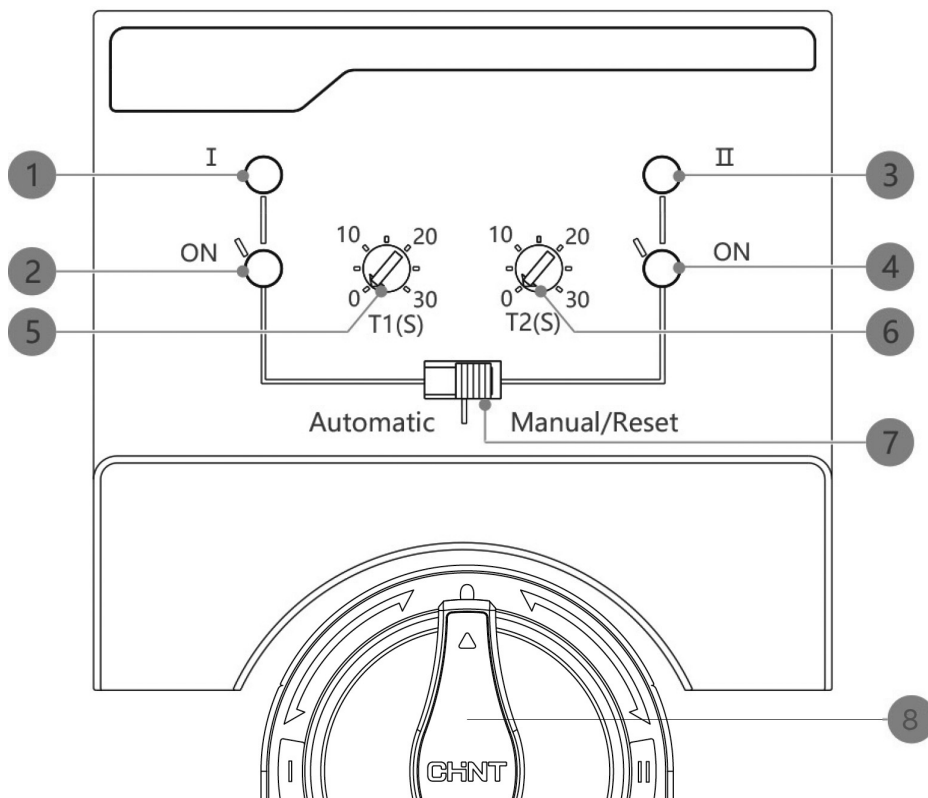

- 1 Affichage de la **tension du réseau**  
La LED s'allume en rouge lorsque **la tension du réseau public est présente.**
- 2 Affichage pour l'alimentation en **courant du réseau public**  
La LED s'allume en vert lorsque **l'alimentation électrique du réseau est activée.**  
**Position du commutateur vers la gauche**
- 3 Affichage de la **tension dans le chemin backup**  
La LED s'allume en rouge lorsque **la tension est présente sur le chemin backup.**
- 4 Affichage pour l'**alimentation de secours du réseau**  
La LED s'allume en vert lorsque **l'alimentation de secours du réseau est activée.**  
**Position du commutateur vers la droite**
- 5 Réglage de la temporisation de commutation pour le passage du fonctionnement couplé au réseau au fonctionnement de remplacement du réseau
- 6 Réglage de la temporisation de retour pour la commutation du mode de remplacement du réseau au mode couplé au réseau
- 7 Commutation automatique/manuelle
- 8 Commutateur entre l'alimentation électrique par le réseau public et le mode de remplacement du réseau

## DISTANCE DE MONTAGE ET DIMENSIONS

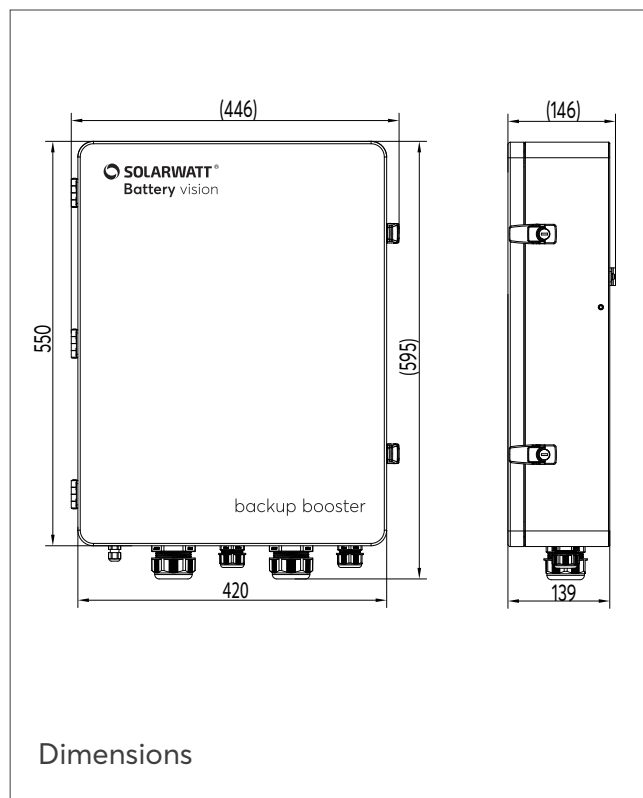
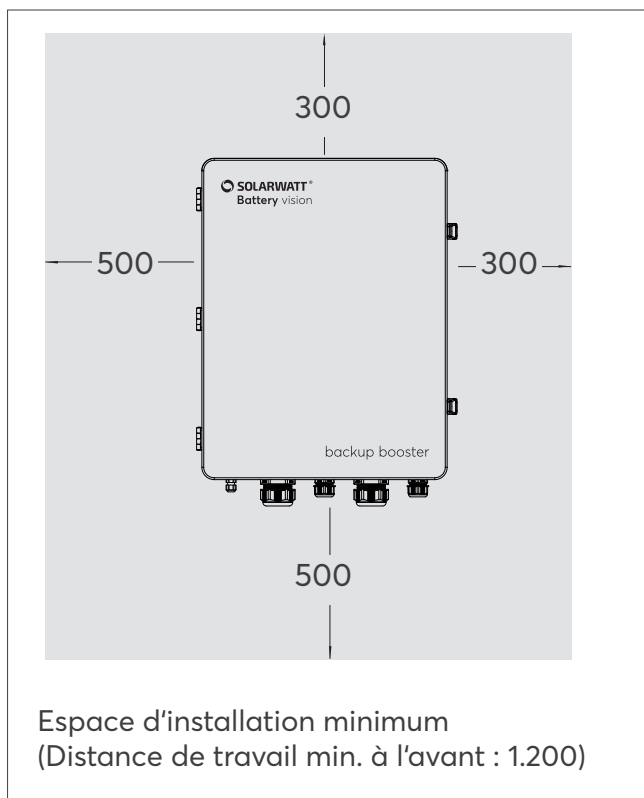

## MONTAGE

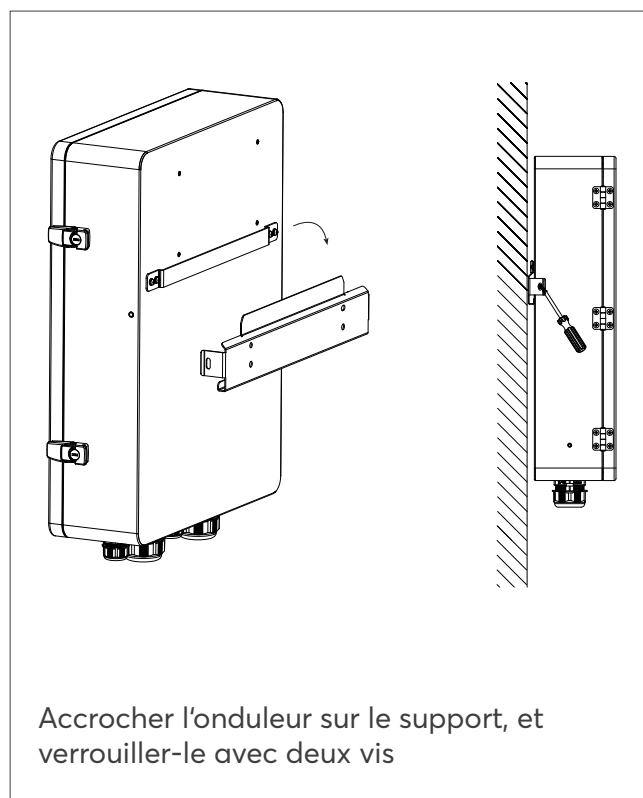
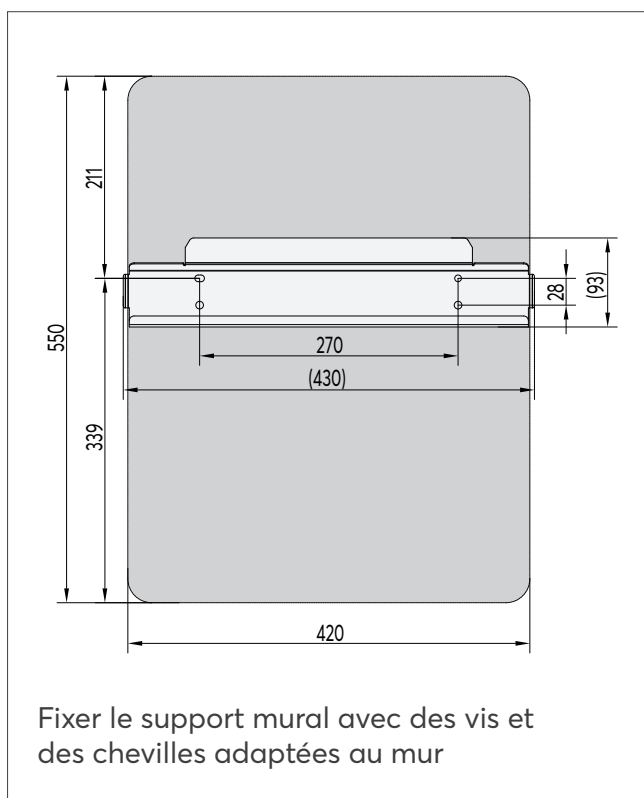

## INSTALLATION ENTRE LA DISTRIBUTION DOMESTIQUE ET INVERTER VISION

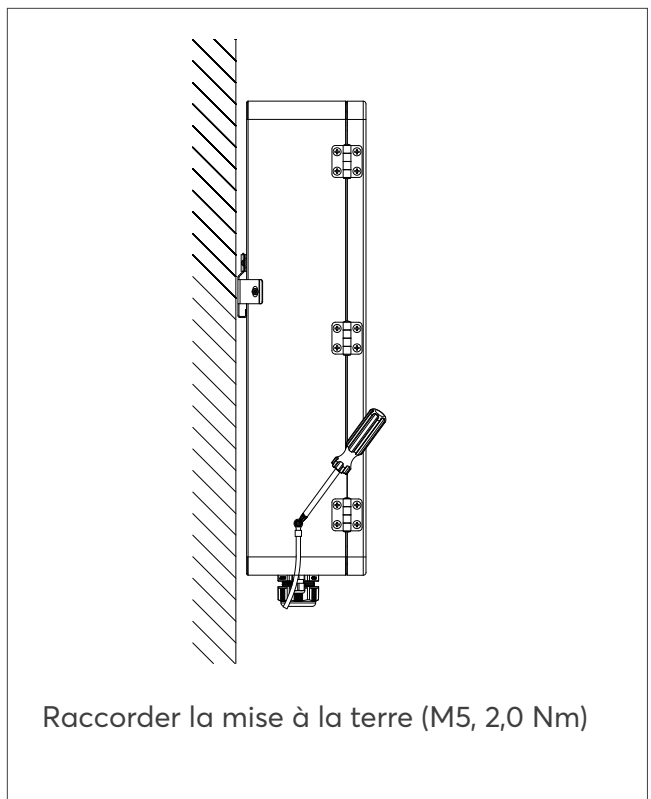
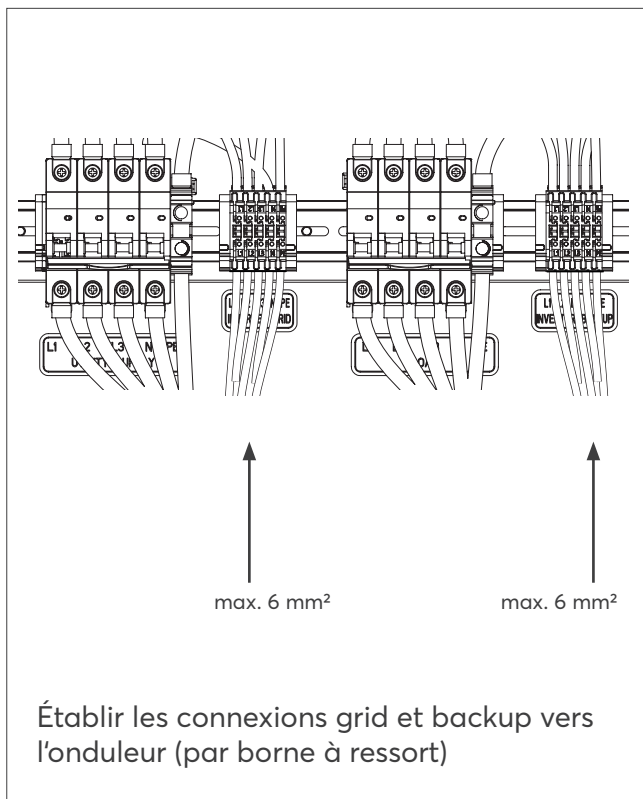
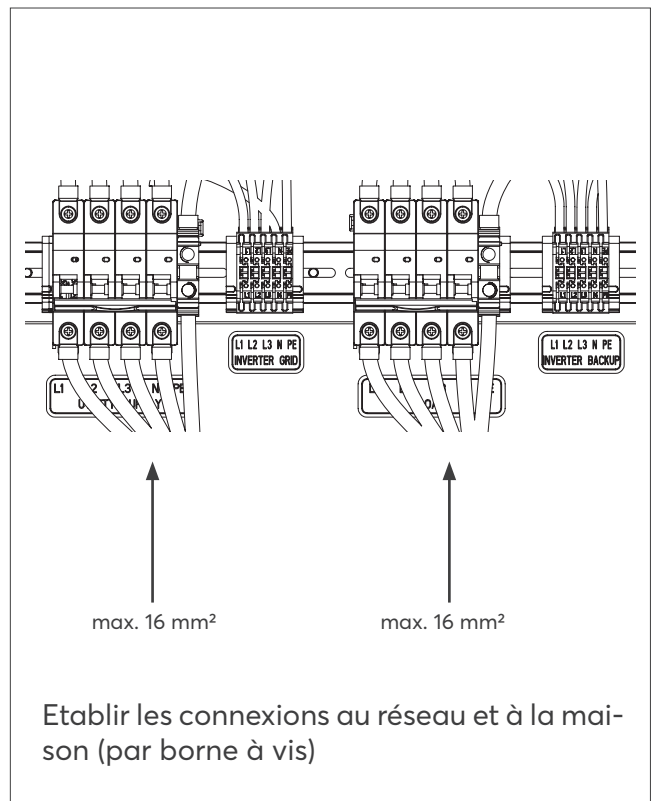
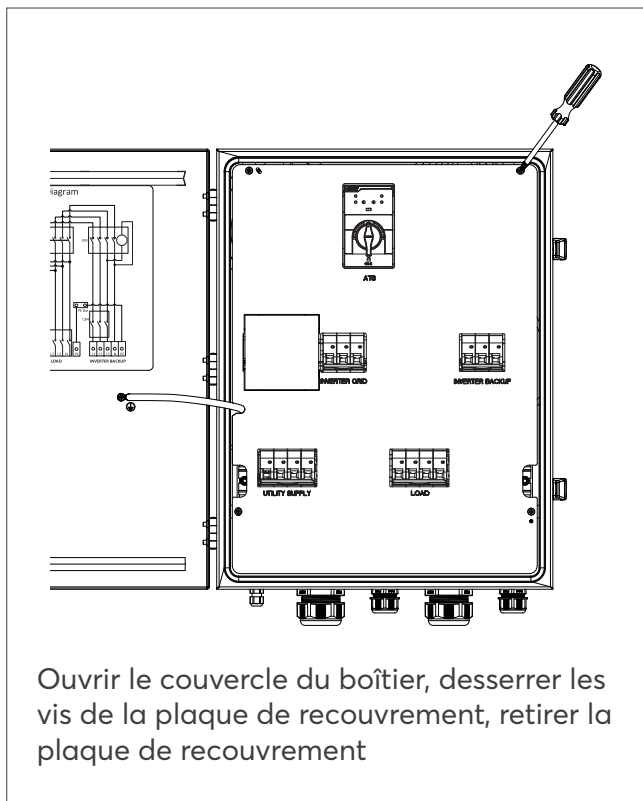

## INSTALLATION ENTRE LA DISTRIBUTION DOMESTIQUE ET INVERTER VISION

- Vérifier que l'appareil est installé de manière sûre et fiable.
- Vérifier que le câble de mise à la terre est raccordé correctement, fermement et de manière fiable.
- Vérifier que tous les câbles sont raccordés correctement, fermement et de manière fiable et que l'ordre des phases est correct.

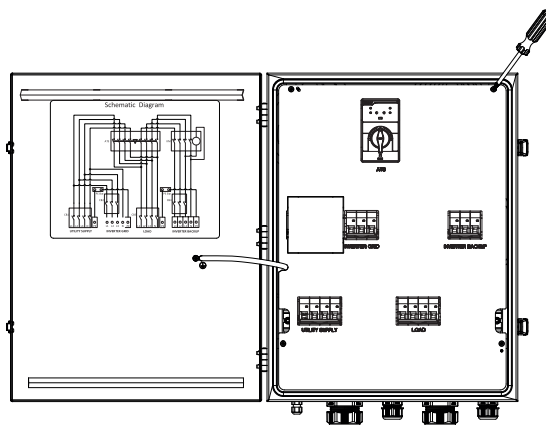

Fermer le couvercle

## DÉMARRAGE DU SYSTÈME

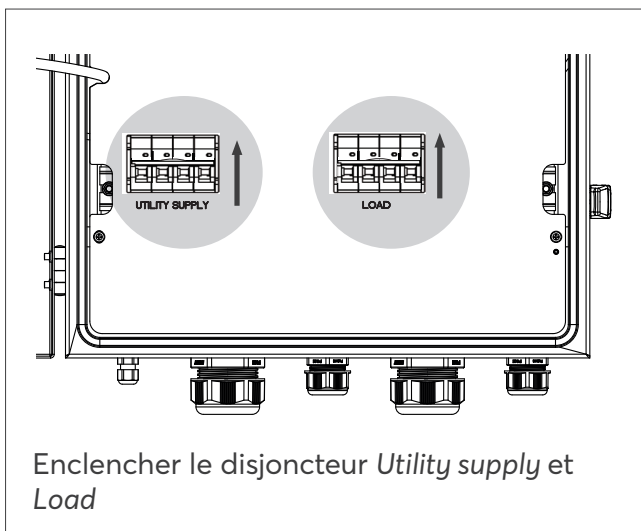

Enclencher le disjoncteur *Utility supply* et *Load*

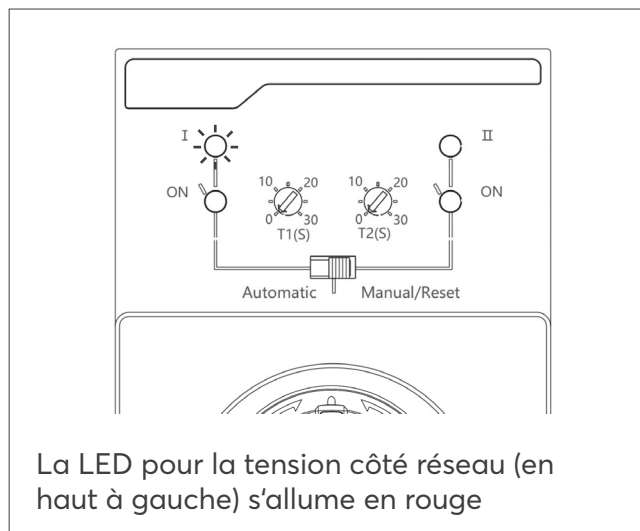

La LED pour la tension côté réseau (en haut à gauche) s'allume en rouge

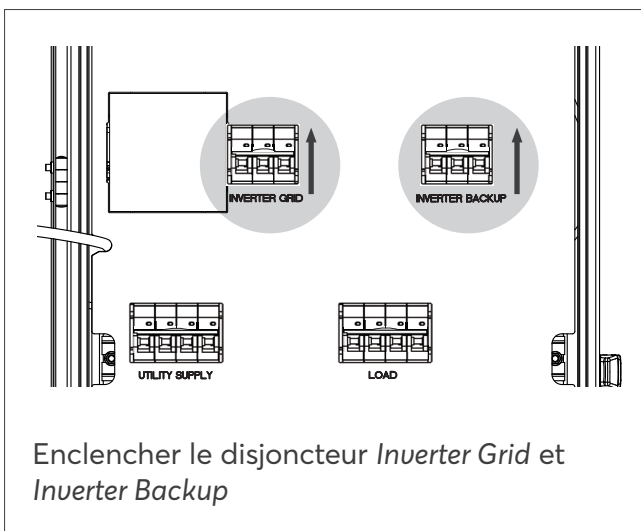

Enclencher le disjoncteur *Inverter Grid* et *Inverter Backup*



Démarrer Inverter vision three et Battery vision conformément au manuel en ligne

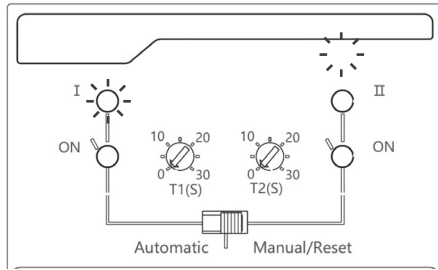

Lorsque l'onduleur démarre, la LED de tension sur le chemin du backup (en haut à droite) s'allume en rouge.

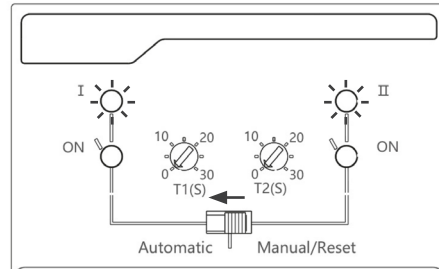

Faire passer l'interrupteur à coulisse de „Manual“ à „Automatic“.

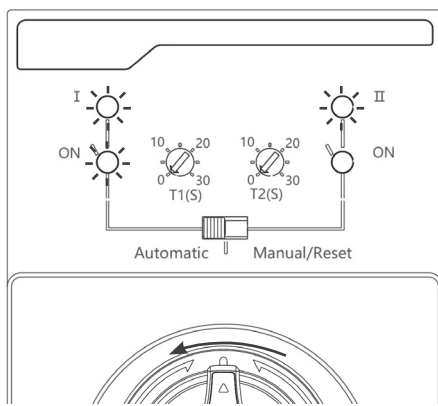

Le commutateur se tourne vers la gauche, la LED pour l'alimentation électrique à partir du réseau public (en bas à gauche) s'allume en vert.

## TEST DU MODE DE REMPLACEMENT DU RÉSEAU

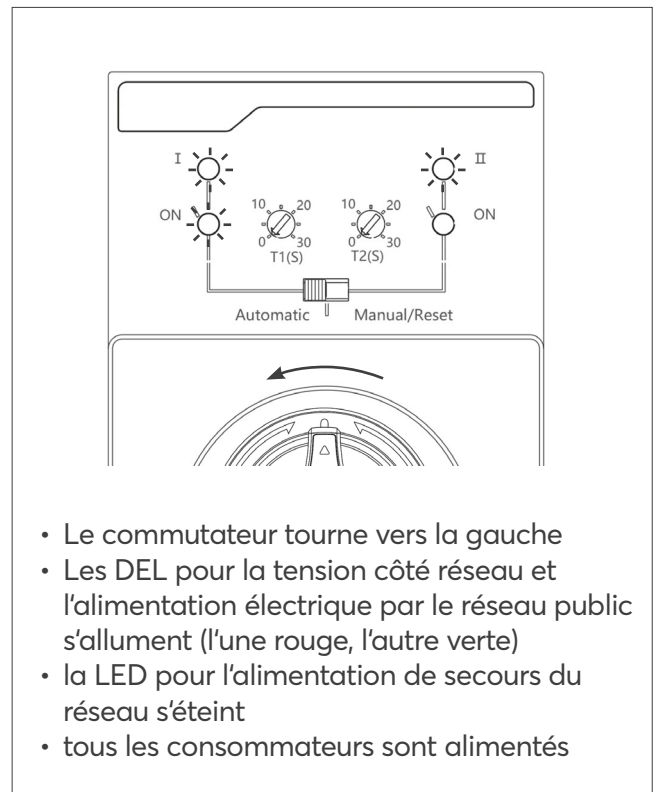
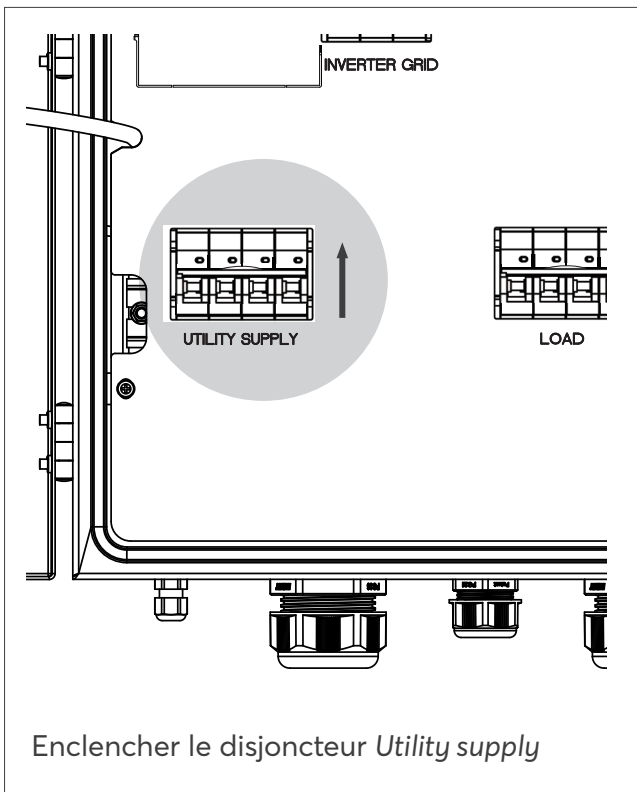
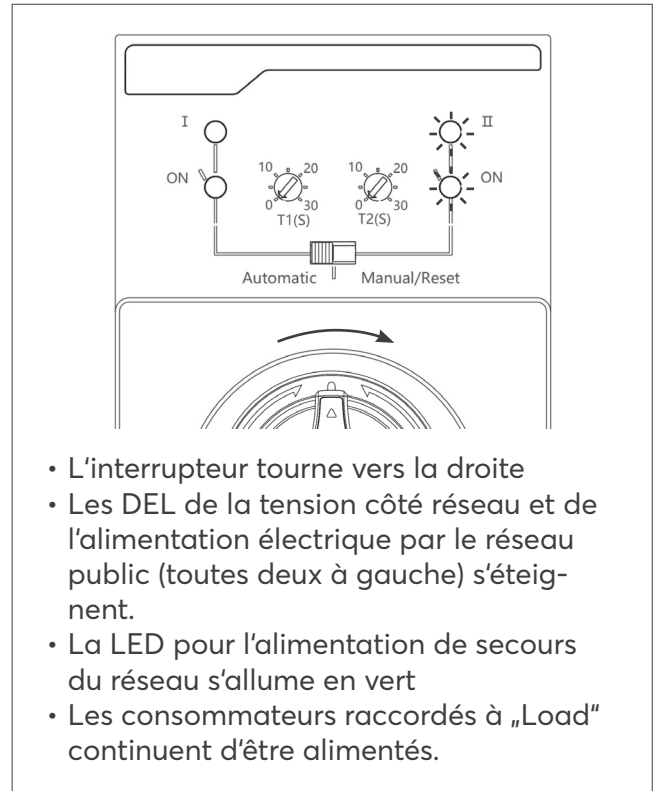
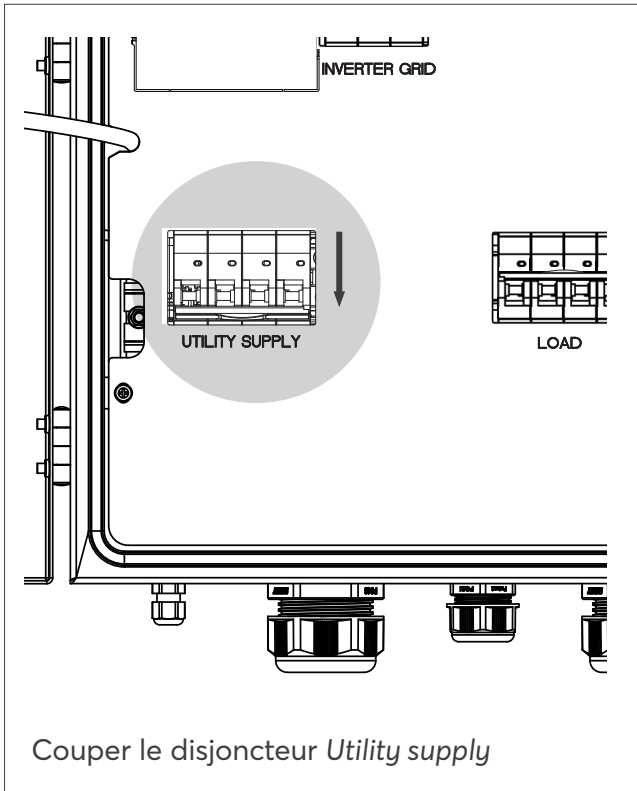



Elimination comme déchet électrique

Battery vision three backup booster

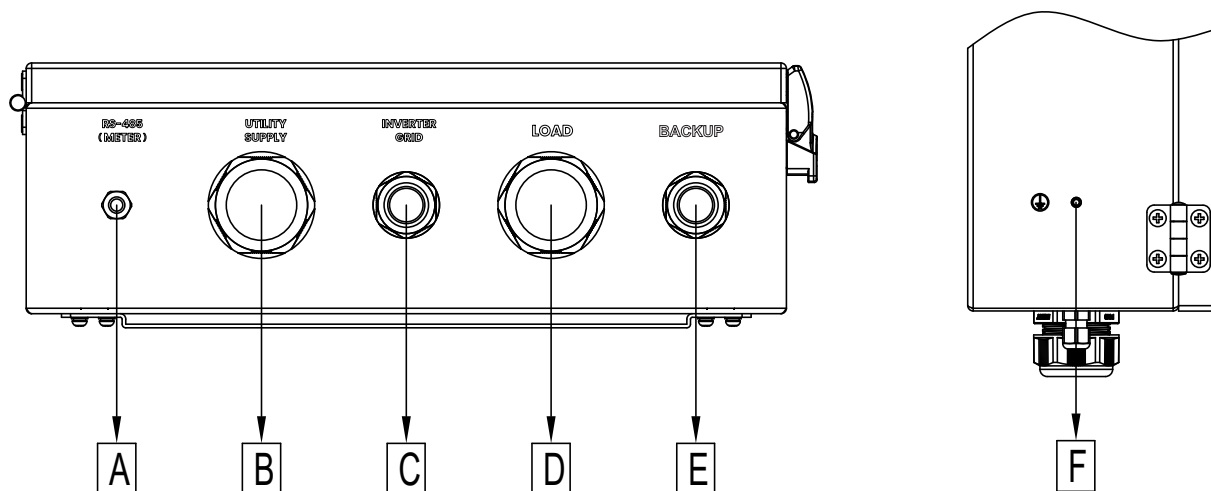

- |   |                                   |  |
|---|-----------------------------------|--|
| A COLLEGAMENTO RS485 (CONTATORE) OPZIONALE* | C COLLEGAMENTO GRID DELL'INVERTER | E COLLEGAMENTO DI BACKUP DELL'INVERTER |
| B COLLEGAMENTO ALLA RETE                    | D COLLEGAMENTO ALLA CASA          | F MESSA A TERRA                        |

\* L'ingresso A (contatore) non è utilizzato, il contatore (Chint Meter DTSU 666) è collegato all'inverter.

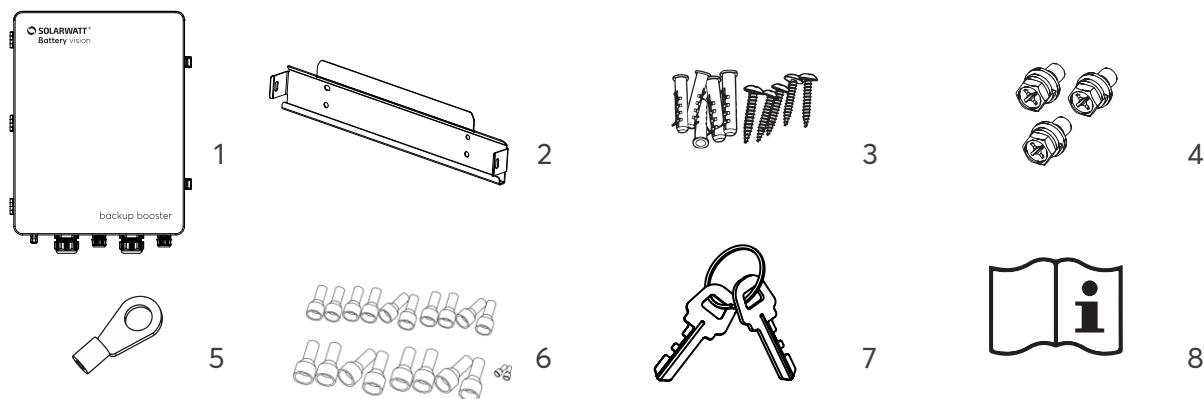

- |  |                                       |  |
|--|---------------------------------------|--|
| 1 Battery vision three backup booster  | 5 Capocorda per cavo di messa a terra | 7 Chiave                               |
| 2 Staffa a parete  | 6 Ghiera per cavi (20x)               | 8 Guida rapida Istruzioni di sicurezza |
| 3 Viti e tasselli<br>4x per il montaggio a parete  |                                       |  |
| 4 Viti<br>2x per il fissaggio del backup booster alla staffa a parete, 1x per la messa a terra |                                       |  |

Impostazioni e funzioni

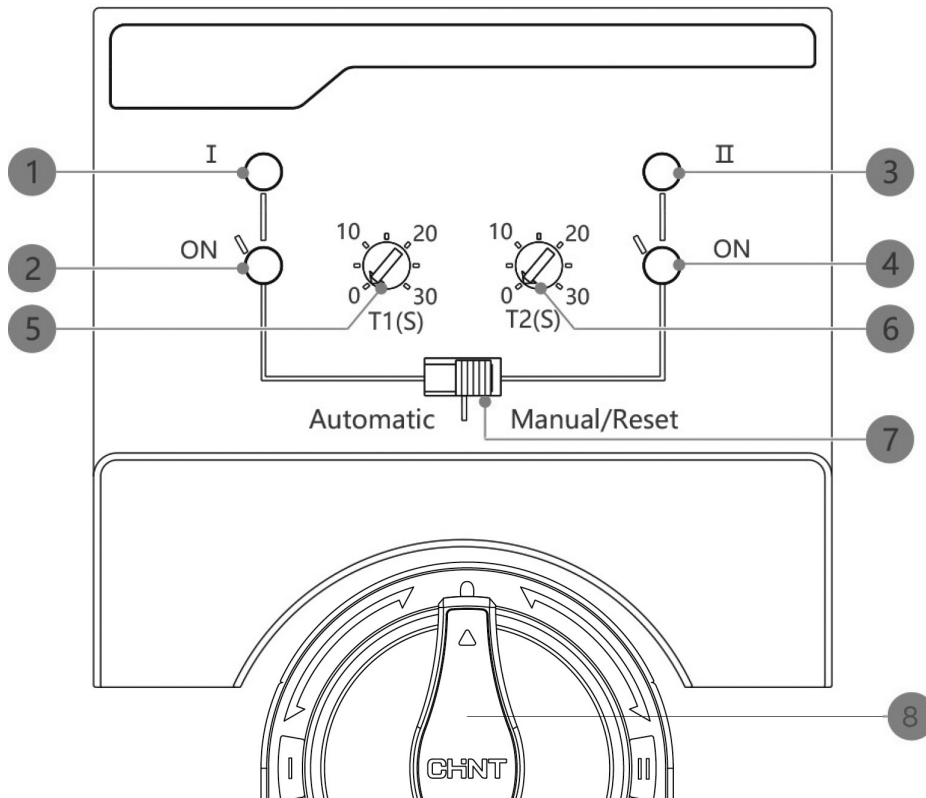

- 1 Visualizzazione per **la tensione di rete**  
Il LED si illumina di rosso quando è presente **la tensione della rete pubblica.**
- 2 Visualizzazione **dell'alimentazione dalla rete pubblica**  
Il LED si illumina di verde quando **l'alimentazione di rete è inserita.**  
**Posizione dell'interruttore a sinistra**
- 3 Visualizzazione della **tensione nel percorso di backup**  
Il LED si accende in rosso quando è presente **la tensione sul percorso di backup**
- 4 Visualizzazione per **l'alimentazione di riserva della rete**  
Il LED si illumina di verde quando **l'alimentazione di riserva di rete è inserita**  
**Posizione dell'interruttore a destra**
- 5 Impostazione del ritardo di commutazione per il passaggio dal funzionamento con accoppiamento di rete al funzionamento con backup di rete
- 6 Impostazione del ritardo di ritorno per il passaggio dal funzionamento con alimentazione di backup di rete al funzionamento con collegamento alla rete
- 7 Commutazione automatica/manuale
- 8 Commutazione tra l'alimentazione dalla rete pubblica e la modalità di backup di rete

## DISTANZA DI MONTAGGIO E DIMENSIONI

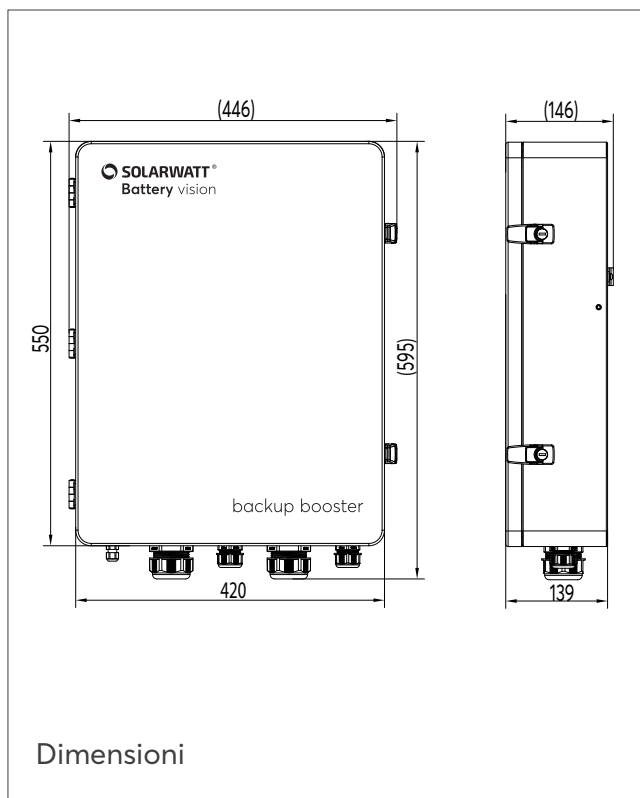
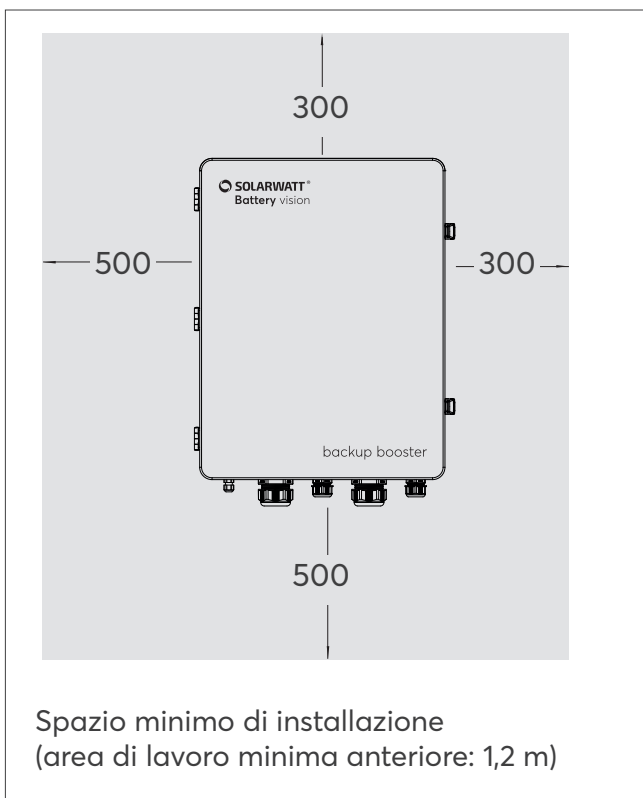

## MONTAGGIO

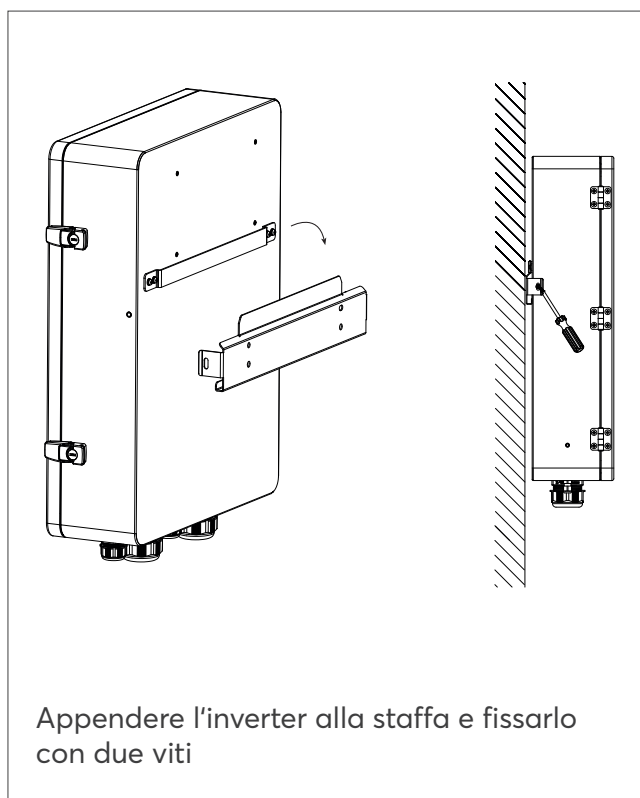
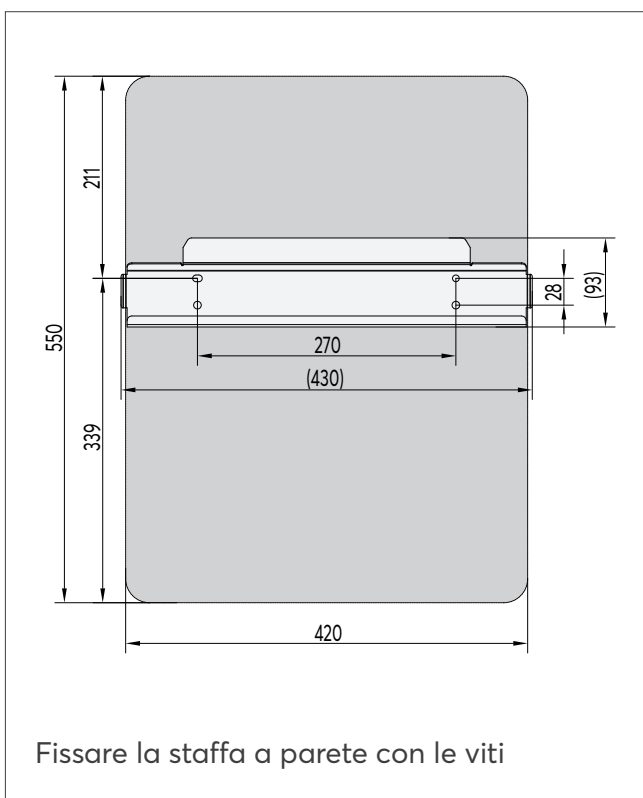

## INSTALLAZIONE TRA LA DISTRIBUZIONE DOMESTICA E L'INVERTER VISION

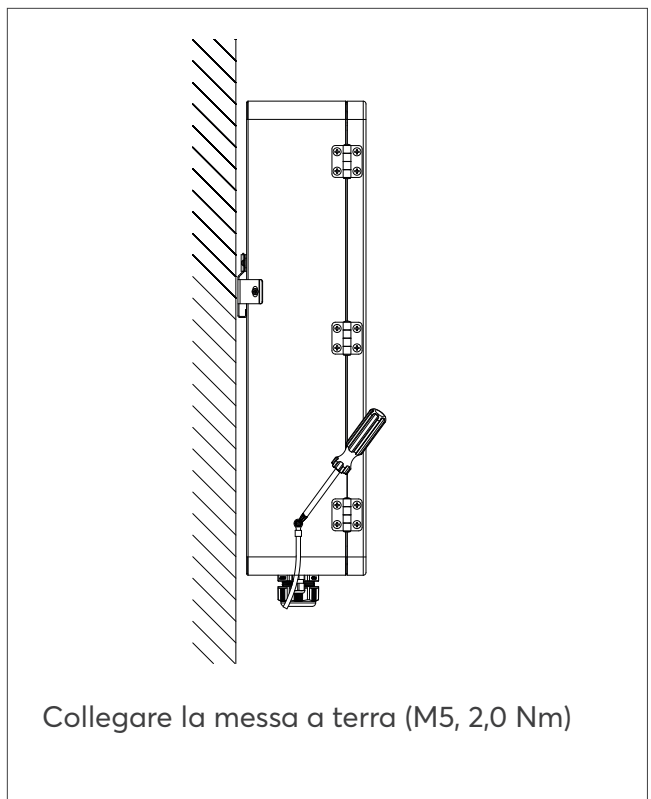
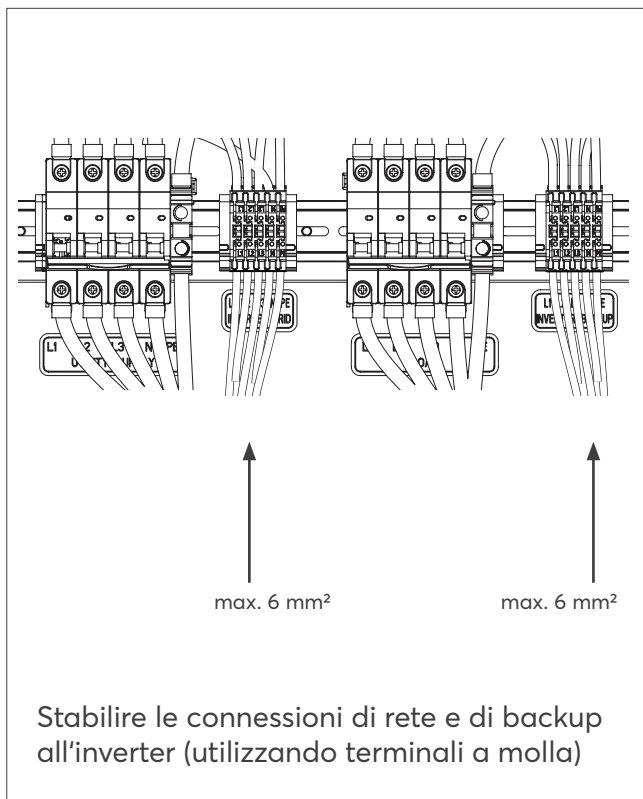
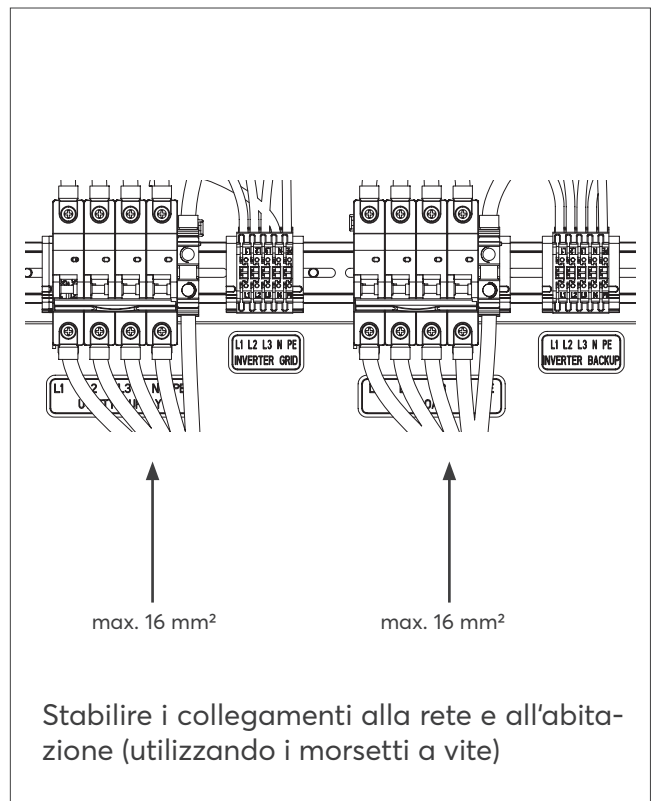
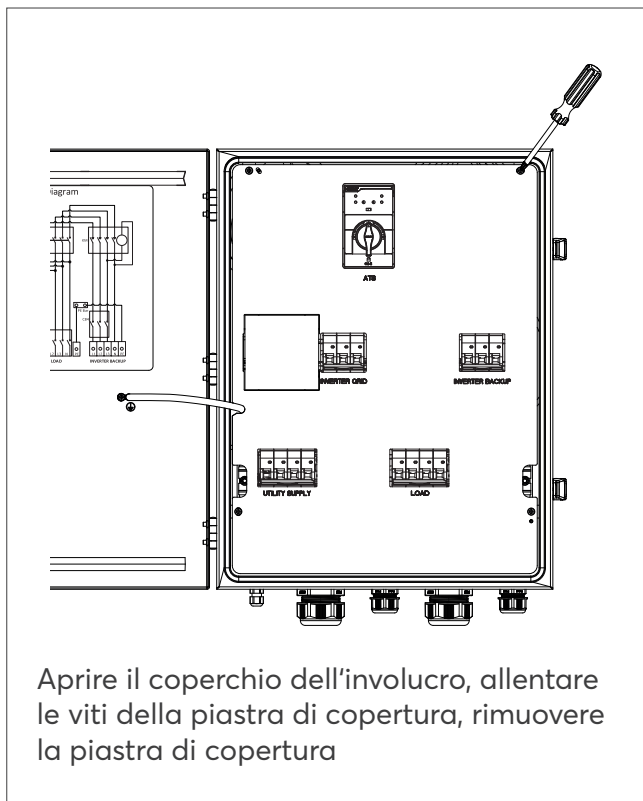

## INSTALLAZIONE TRA LA DISTRIBUZIONE DOMESTICA E L'INVERTER VISION

- Verificare che l'apparecchio sia installato in modo sicuro e affidabile.
- Verificare che il cavo di messa a terra sia collegato in modo corretto, sicuro e affidabile.
- Verificare che tutti i cavi siano collegati in modo corretto, sicuro e affidabile e che la sequenza delle fasi sia corretta.

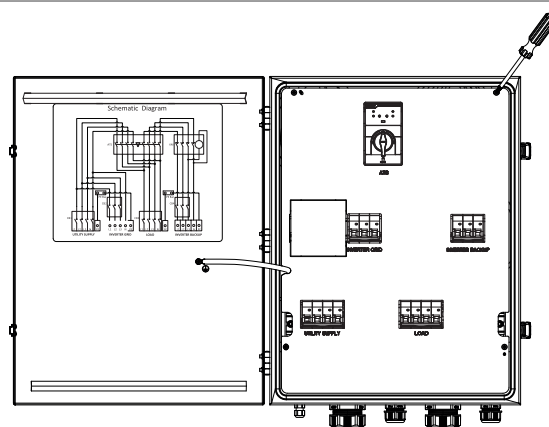

Chiudere la piastra di copertura

## AVVIO DEL SISTEMA

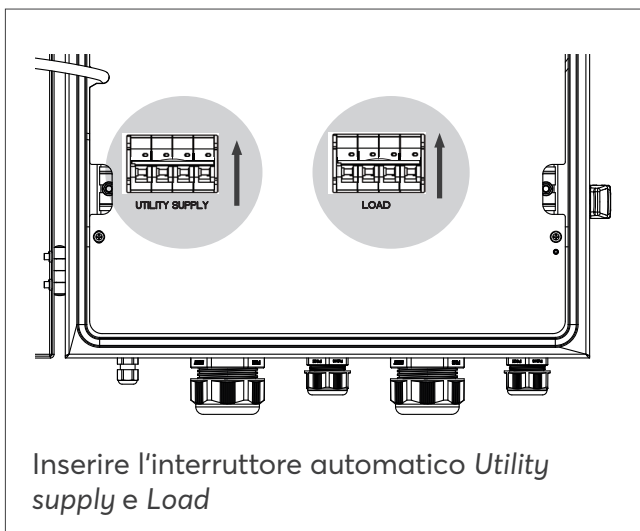

Inserire l'interruttore automatico *Utility supply* e *Load*

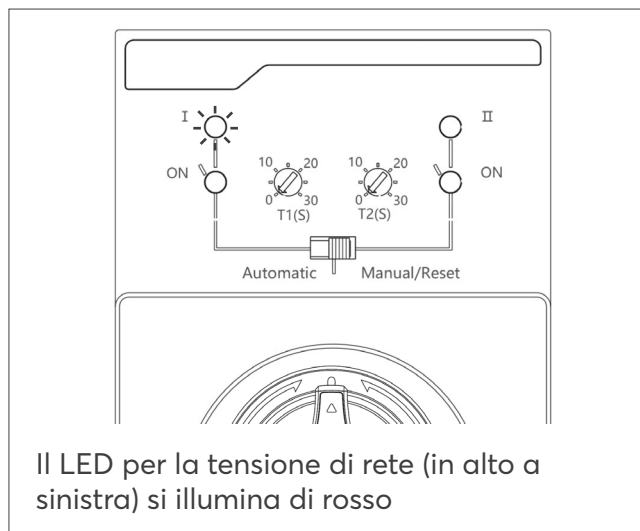

Il LED per la tensione di rete (in alto a sinistra) si illumina di rosso

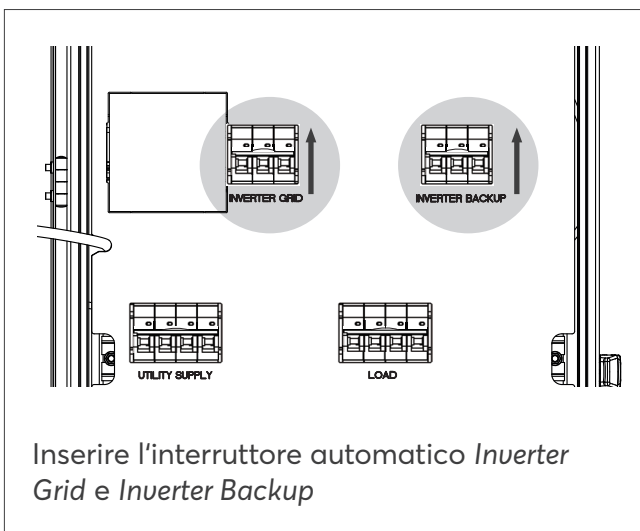

Inserire l'interruttore automatico *Inverter Grid* e *Inverter Backup*



Avviare *Inverter vision three* e *Battery vision* secondo il manuale online

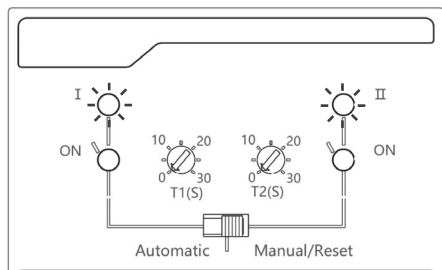

Quando l'inverter si avvia, il LED della tensione sul percorso di backup (in alto a destra) si illumina di rosso.

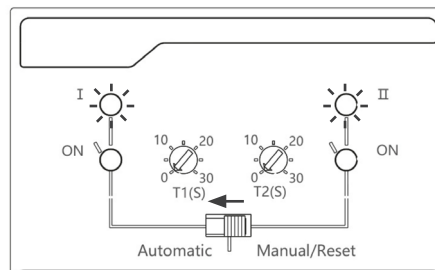

Commutare l'interruttore a scorrimento da „Manuale” ad „Automatico”.

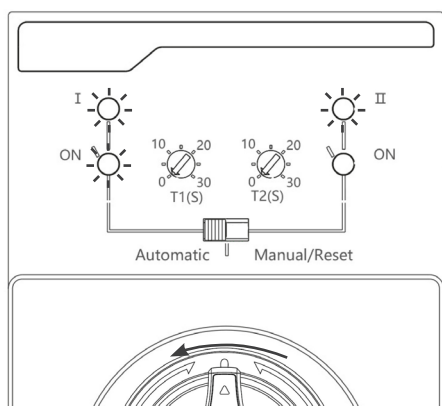

L'interruttore gira a sinistra, il LED per l'alimentazione dalla rete pubblica (in basso a sinistra) si accende di verde.

## TEST DEL FUNZIONAMENTO DEL BACKUP DI RETE

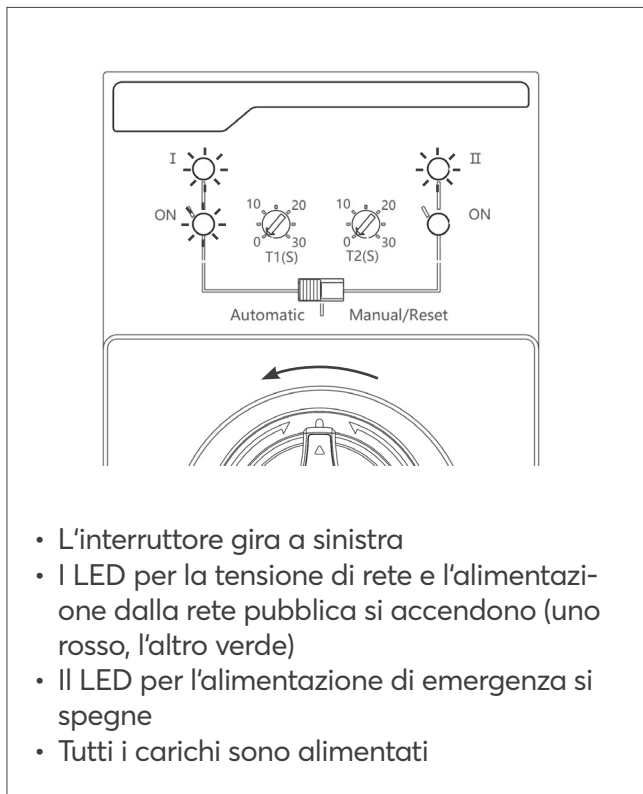
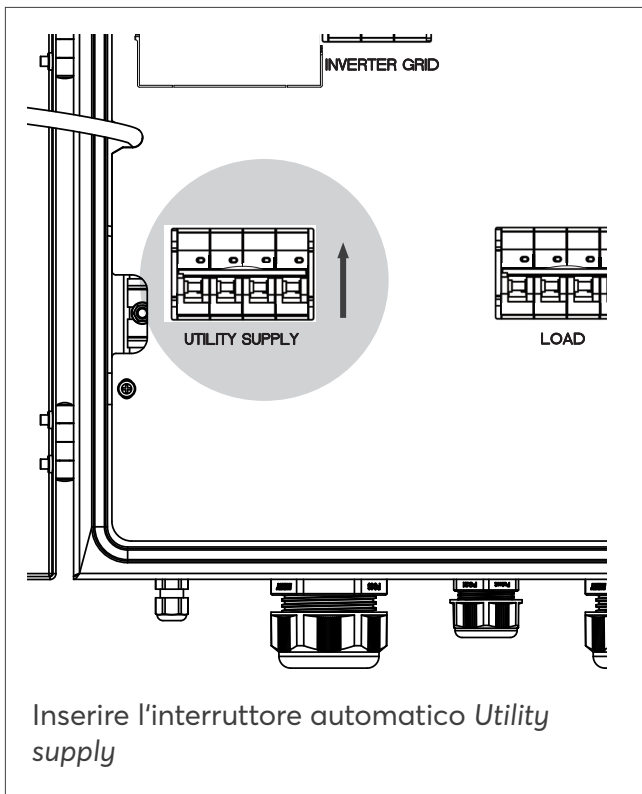
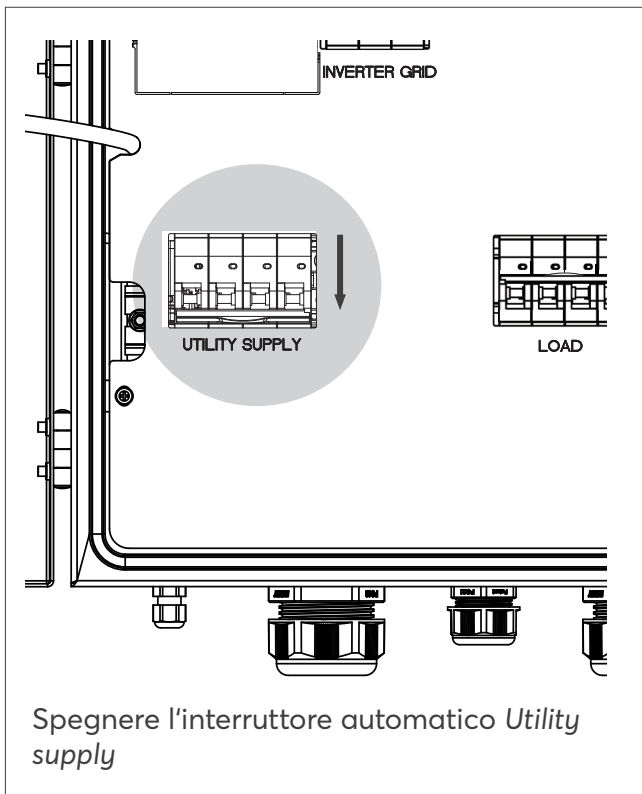



Smaltimento come rifiuto elettrico

## TEKENINGEN EN PAKLIJSTEN VAN HET APPARAAT

### Battery vision three backup booster

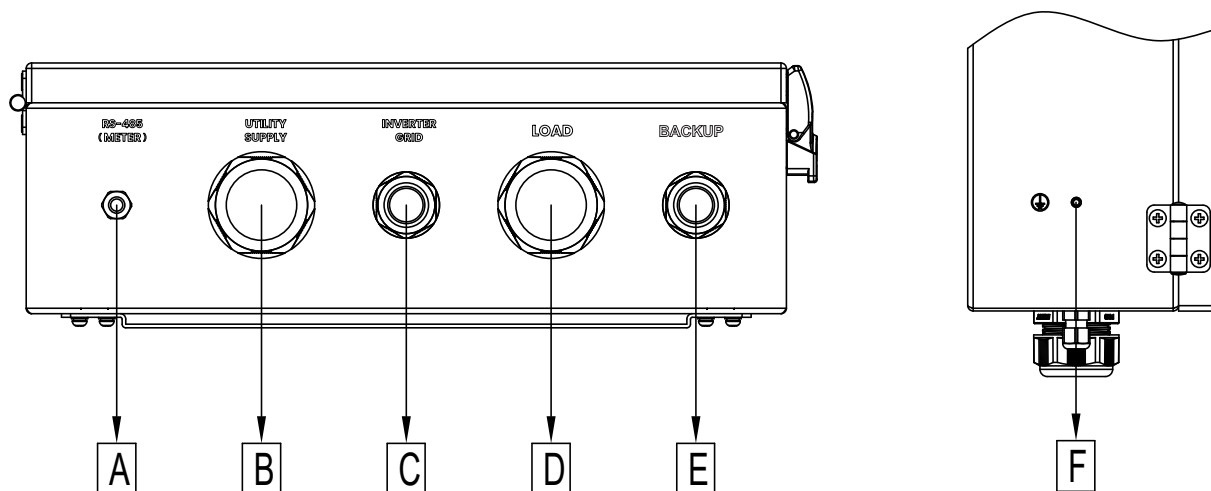

A RS485-AANSLUITING  
(METER) OPTIONEEL\*  
B NETAANSLUITING

C NETAANSLUITING  
VAN DE OMVORMER  
D HUISAANSLUITING

E BACK-UP AANSLUITING  
OMVORMER  
F AARDING

\* Aansluiting A (meter) wordt niet gebruikt, de meter (Chint Meter DTSU 666) is aangesloten op de Inverter vision.

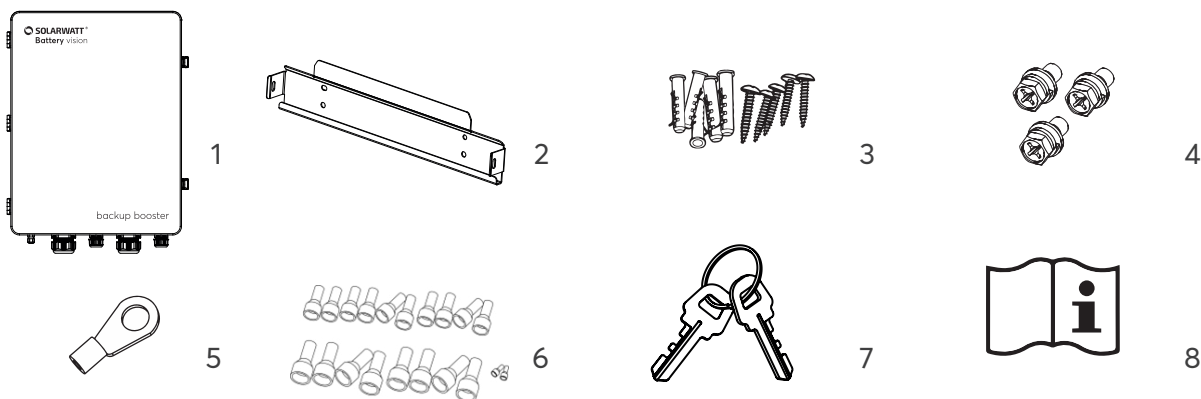

1 Battery vision three backup booster  
2 Bevestigingsbeugel  
3 Schroeven en pluggen  
4x voor wandbevestiging  
4 Schroeven  
2x voor bevestiging backup booster aan bevestigingsbeugel, 1x aarding

5 Kabelschoen voor  
aardingskabel  
6 Adereindhulzen (20x)

7 Sleutel  
8 Snelstartgids  
Veiligheidsinstructies

### Instellingen en functies

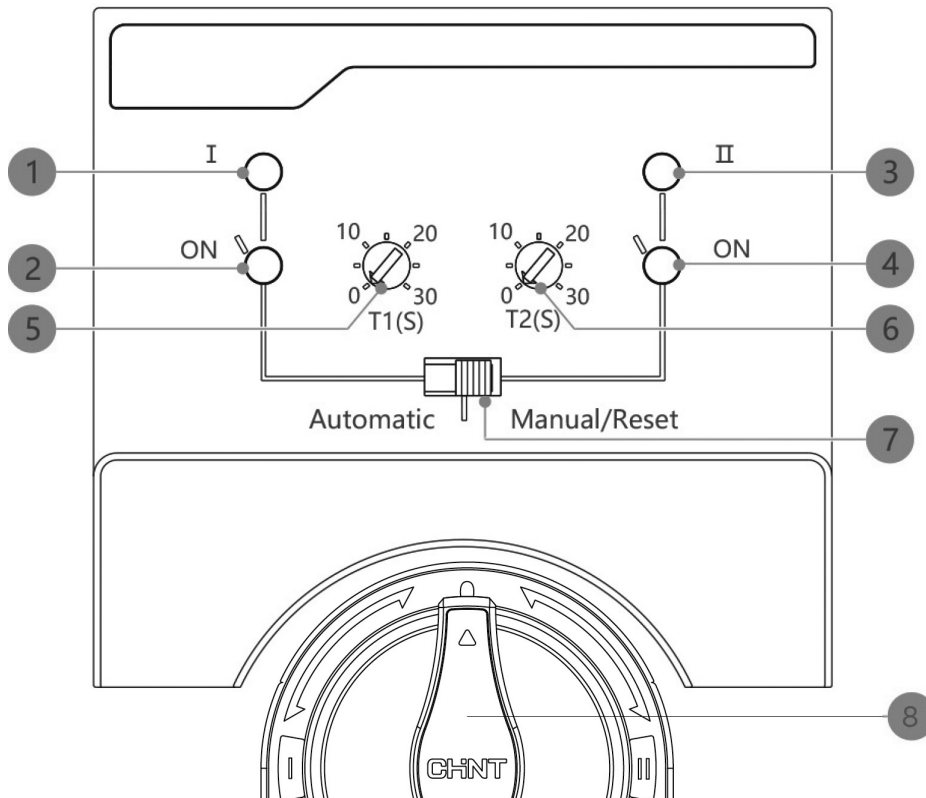

- 1 Indicator voor **netspanning**  
LED brandt rood als er **spanning van het openbare elektriciteitsnet** aanwezig is
- 2 Indicator voor voeding van het openbare stroomnet  
LED brandt groen bij **ingeschakelde netspanning**  
**Schakelaarpositie naar links**
- 3 Indicator voor **spanning in back-up**  
LED brandt rood als er **spanning op de back-upuitgang** aanwezig is
- 4 Indicator voor **netzijdige back-upvoeding**  
LED brandt groen als de **netaansluiting voor back-upvoeding is ingeschakeld**  
**Schakelaarpositie naar rechts**
- 5 Instellen van de omschakelvertragingstijd voor het omschakelen van netgekoppeld bedrijf naar netback-up bedrijf
- 6 Instellen van de terugschakelvertragingstijd voor het omschakelen van netgekoppeld back-up bedrijf naar netgekoppeld bedrijf
- 7 Automatische/handmatige omschakeling
- 8 Schakelaar voor het omschakelen tussen netgekoppeld bedrijf en back-upstroomvoorziening

## MONTAGEAFSTAND EN AFMETINGEN

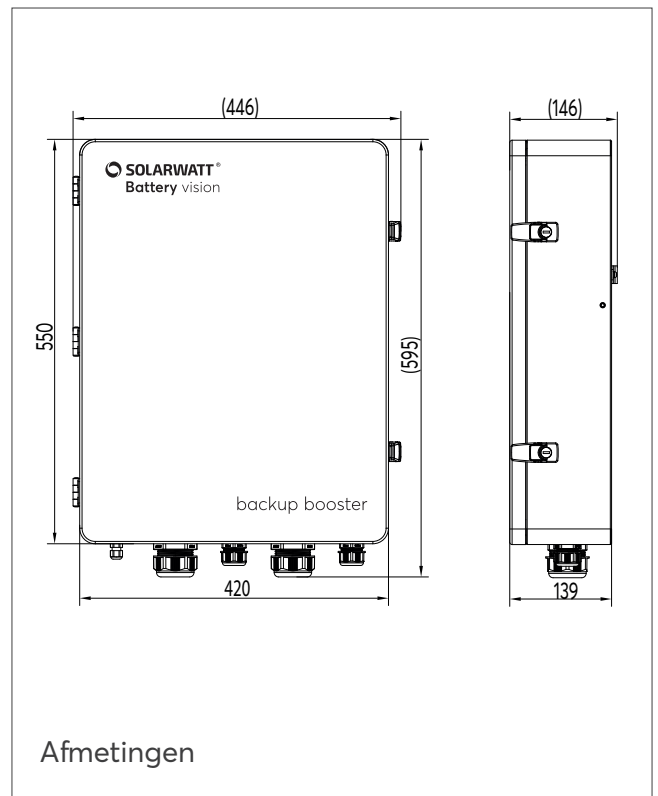
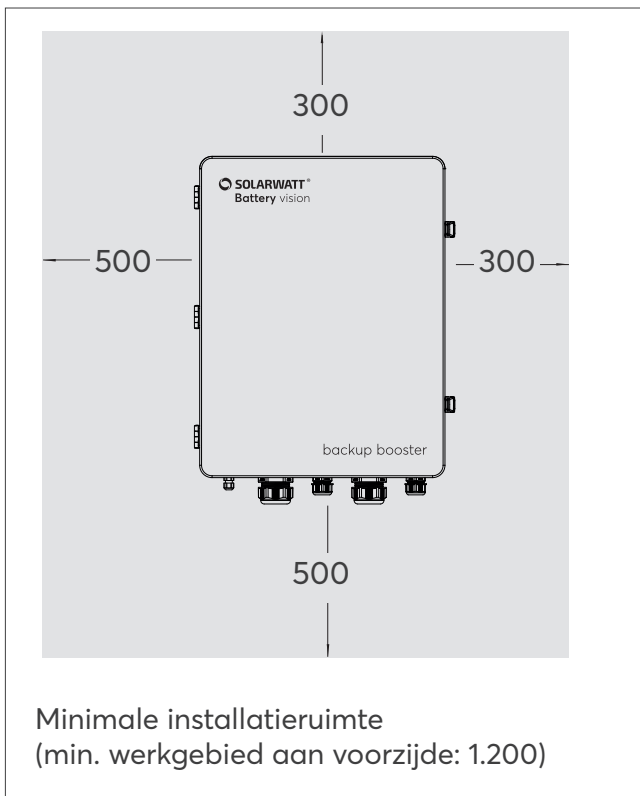

## MONTAGE

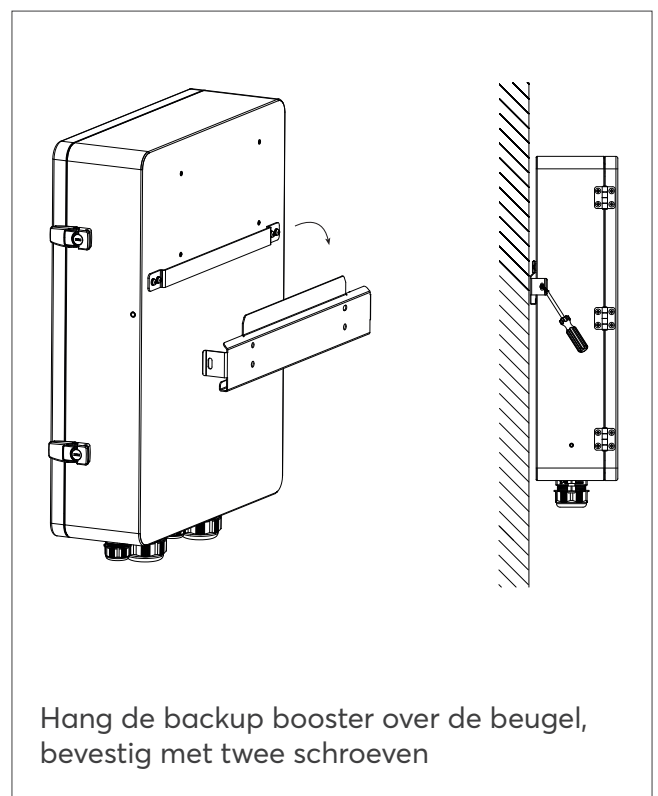
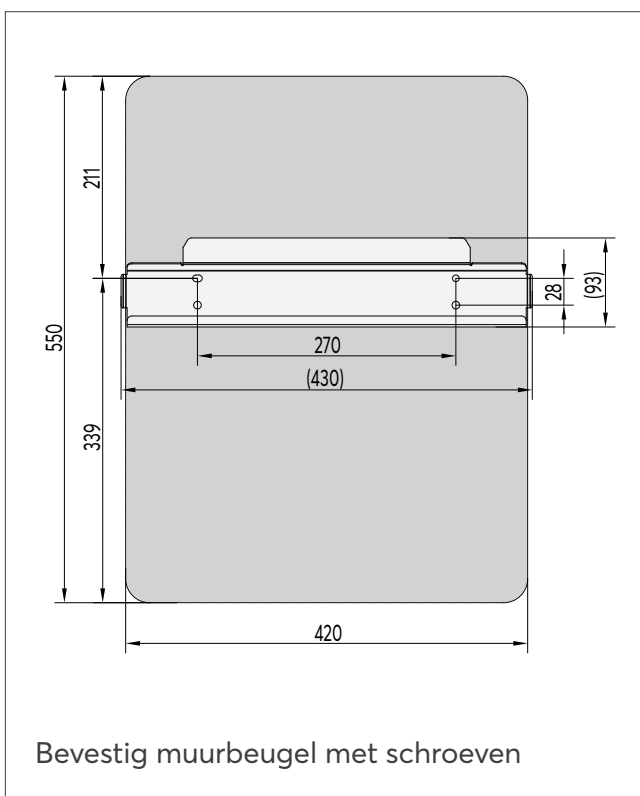

# INSTALLATIE TUSSEN HUISVERDELING EN INVERTER VISION

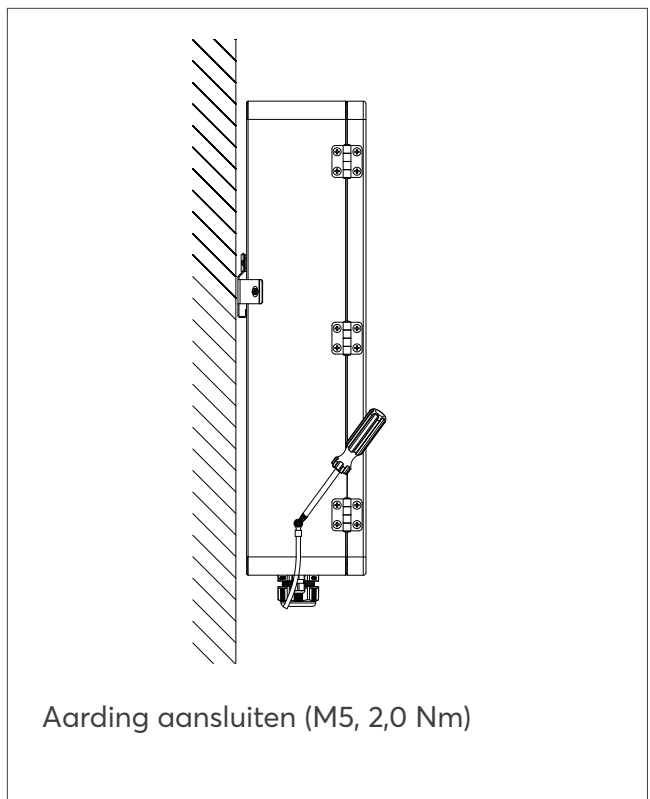
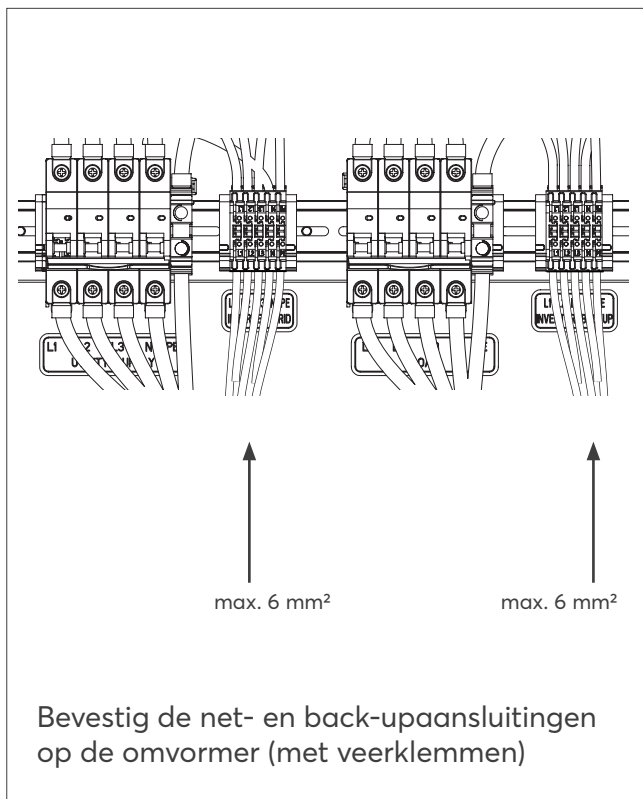
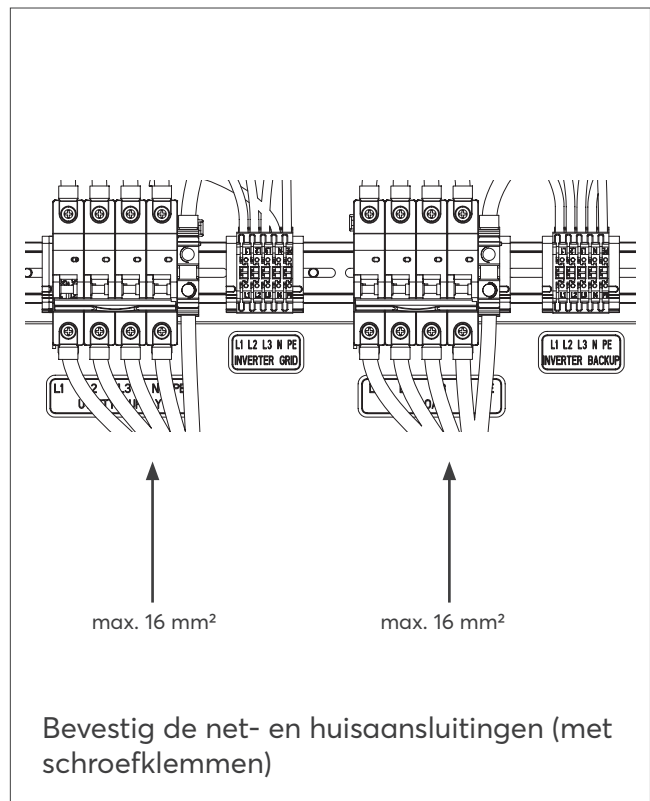
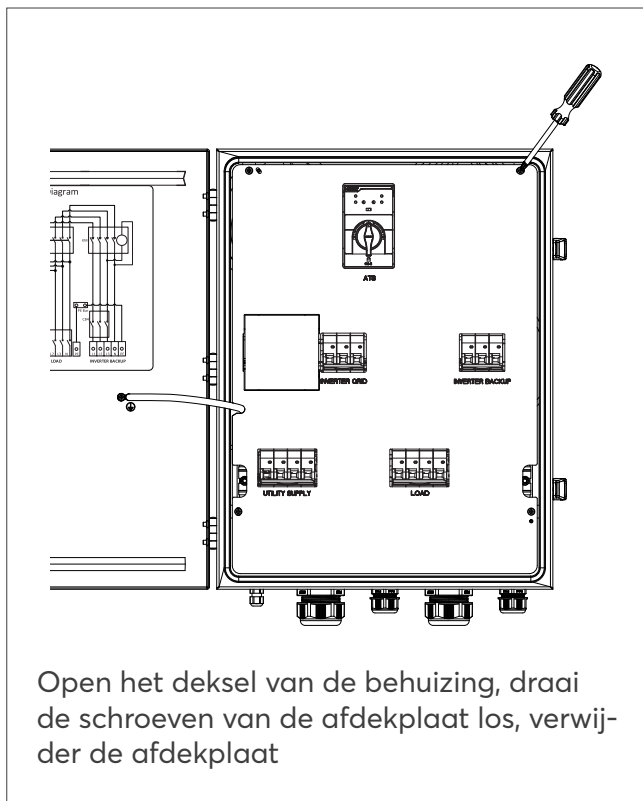

## INSTALLATIE TUSSEN HUISVERDELING EN INVERTER VISION

- Controleer of het apparaat veilig en betrouwbaar geïnstalleerd is.
- Controleer of de aardingskabel correct, veilig en betrouwbaar is aangesloten.
- Controleer of alle kabels correct, veilig en betrouwbaar zijn aangesloten en of de fasevolgorde correct is.

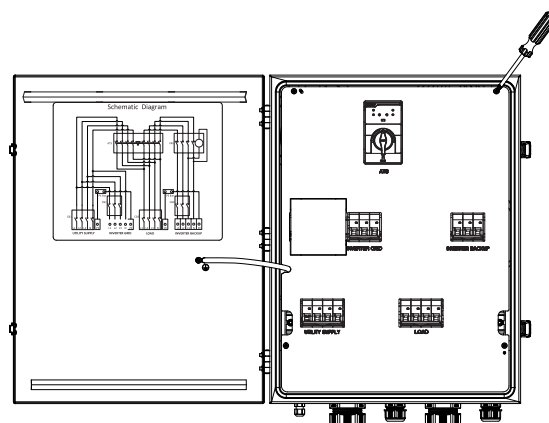

Sluit de afdekplaat

## SYSTEEM STARTEN

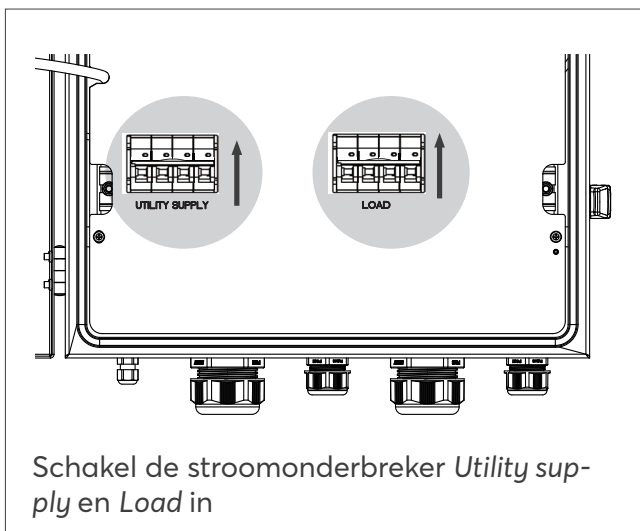

Schakel de stroomonderbreker *Utility supply* en *Load* in

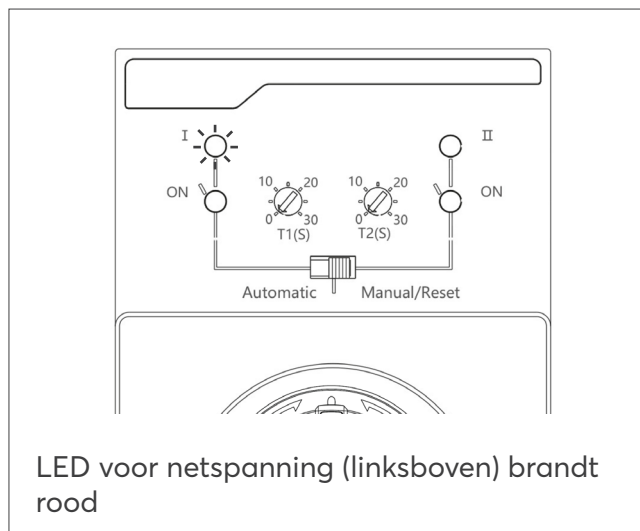

LED voor netspanning (linksboven) brandt rood

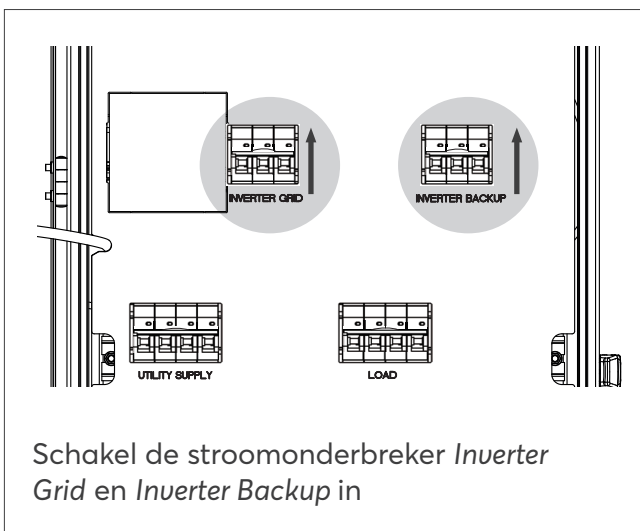

Schakel de stroomonderbreker *Inverter Grid* en *Inverter Backup* in



Inverter vision three en Battery vision starten volgens de online handleiding

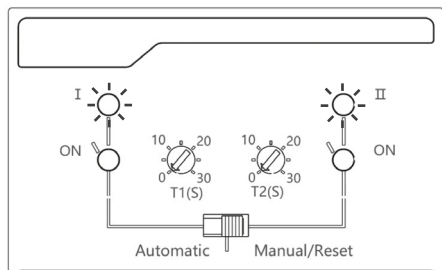

Als de omvormer opstart, brandt de LED voor de spanning op de back-up uitgang (rechtsboven) rood.

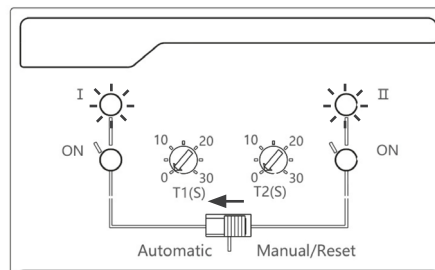

Zet de schuifschakelaar van „Manual“ op „Automatic“.

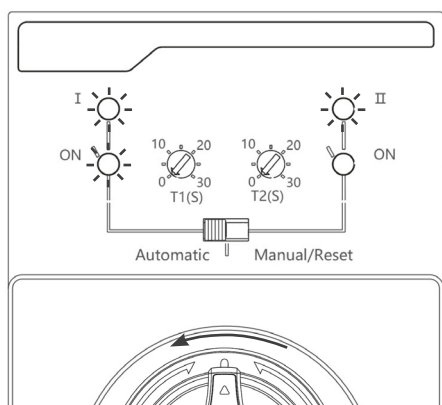

Schakelaar draait naar links, LED voor voeding van het openbare stroomnet (linksonder) brandt groen.

## TEST DE WERKING VAN DE NOODVOEDING

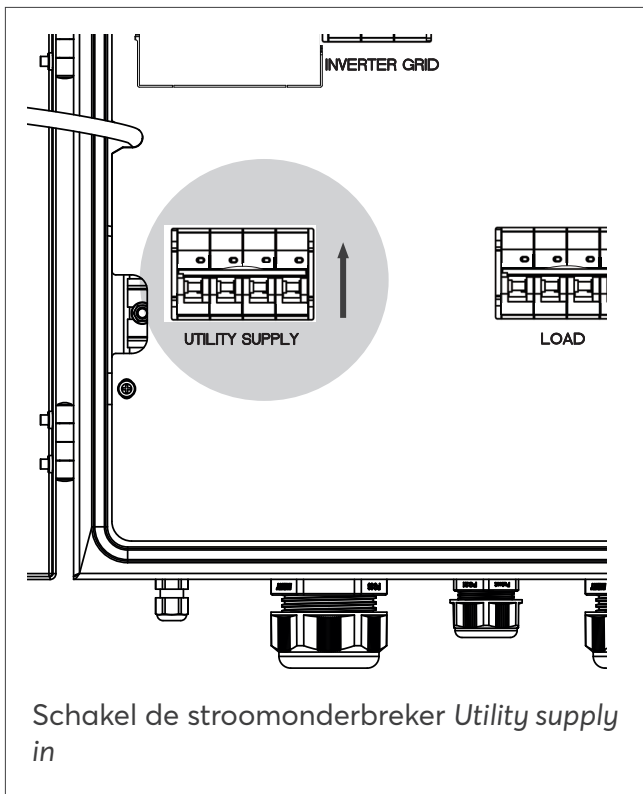
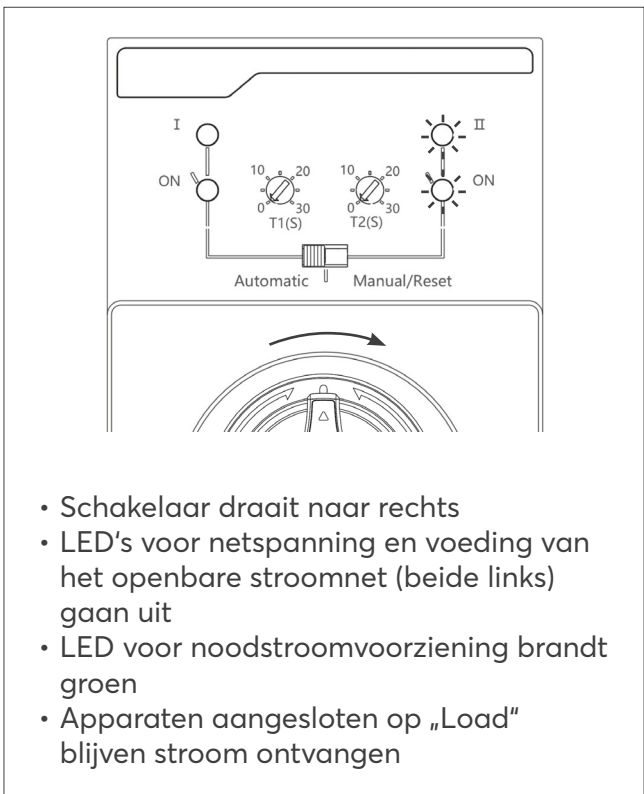
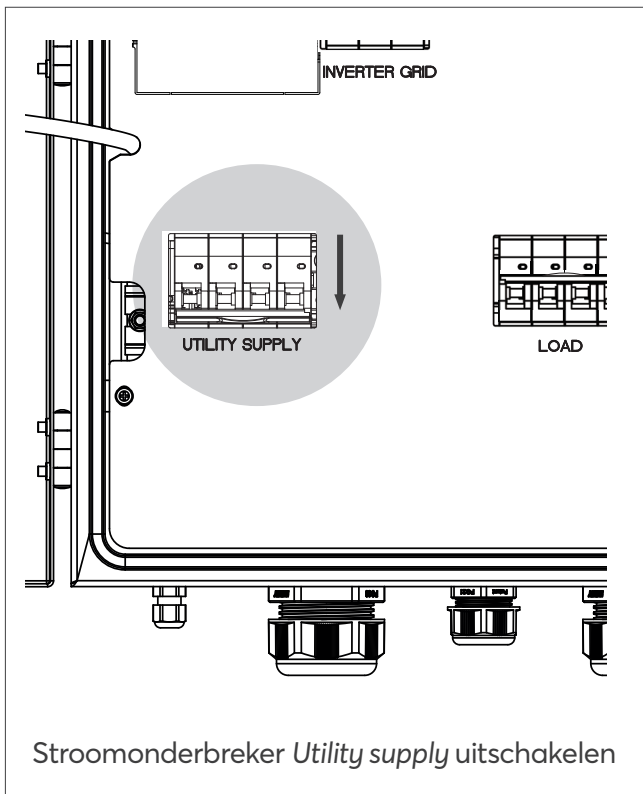



Afvoer als elektrisch afval

## VISTA DEL DISPOSITIVO Y LISTAS DE COMPONENTES

### Battery vision three backup booster

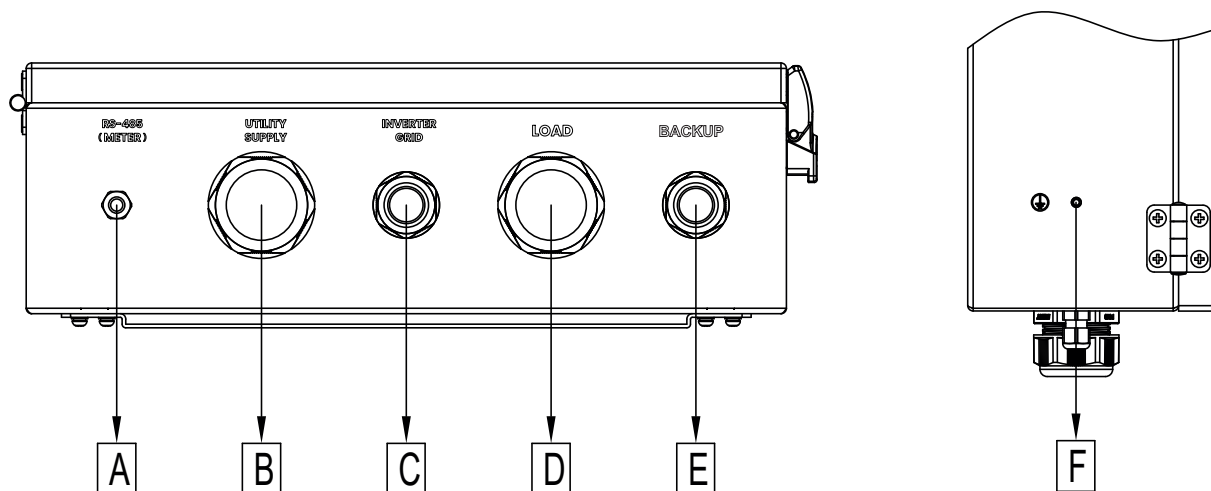

- |                                       |                              |                                   |
|---------------------------------------|------------------------------|-----------------------------------|
| A CONEXIÓN RS485 (CONTADOR) OPCIONAL* | C CONEXIÓN GRID DEL INVERSOR | E CONEXIÓN DE BACKUP DEL INVERSOR |
| B CONEXIÓN A LA RED                   | D CONEXIÓN DOMÉSTICA         | F CONEXIÓN A TIERRA               |

\* La entrada A (contador) no se utiliza, el contador (Chint Meter DTSU 666) está conectado al Inverter vision.

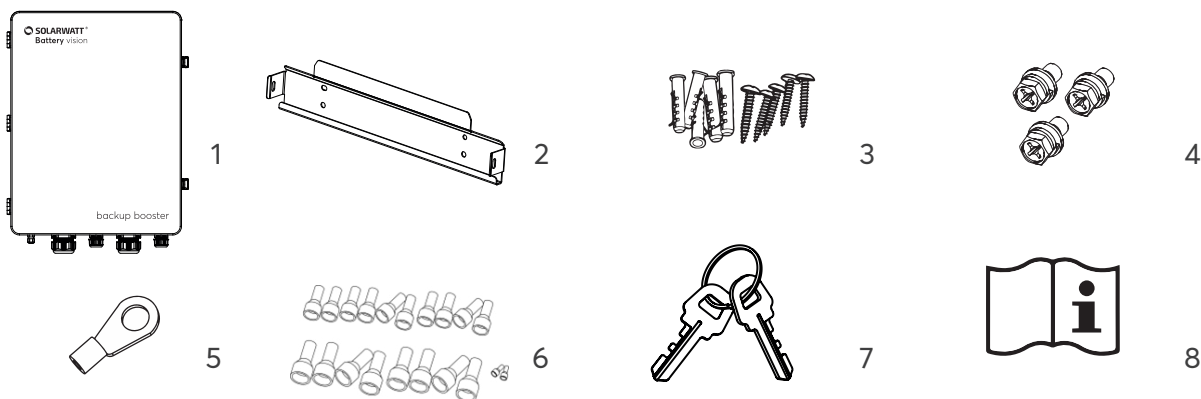

- |  |                                 |                              |
|--|---------------------------------|------------------------------|
| 1 Battery vision three backup booster  | 5 Terminal para cable de tierra | 7 Llave                      |
| 2 Soporte de pared   | 6 Terminales de cable (20x)     | 8 Guía rápida de instalación |
| 3 Tornillos y tacos<br>4x para montaje en pared                                    |                                 | Instrucciones de seguridad   |
| 4 Tornillos<br>2x para fijar el backup booster al soporte mural, 1x toma de tierra |                                 |                              |

Ajustes y funciones

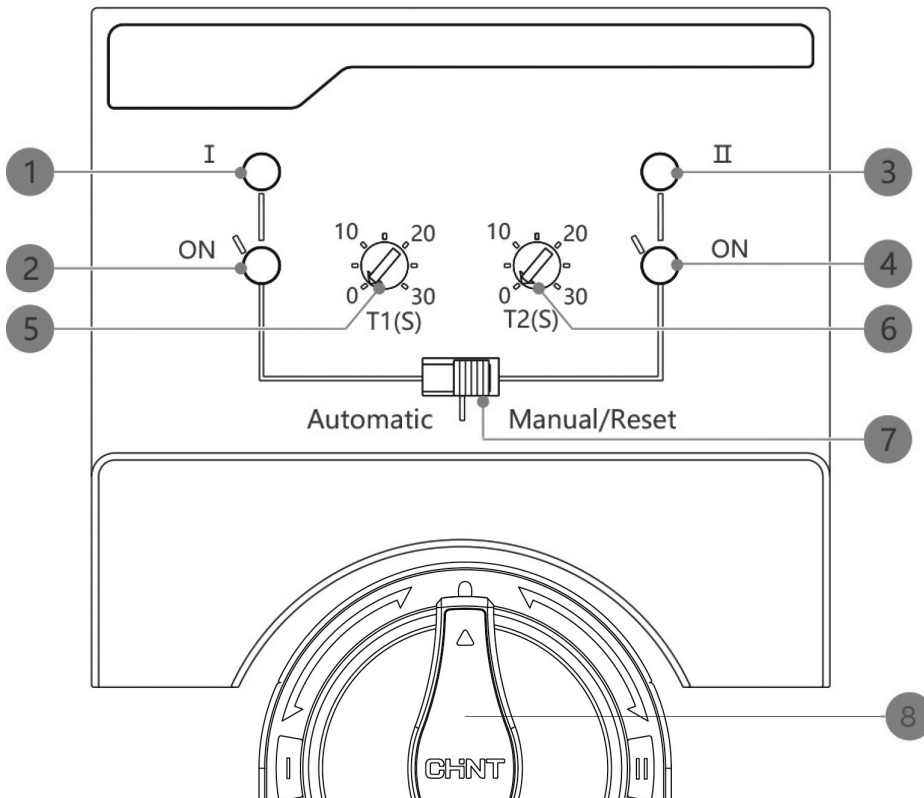

- 1 Indicación de la **tensión de red**  
El LED se ilumina en rojo cuando hay **tensión de la red pública**
- 2 Indicación de **la alimentación de la red pública**  
El LED se ilumina en verde cuando está conectada **la alimentación de la red pública**  
**Posición del interruptor a la izquierda**
- 3 Indicación de **la tensión en el backup**  
El LED se ilumina en rojo cuando hay **tensión en la vía de backup**
- 4 Indicación de **la red de reserva**  
El LED se ilumina en verde cuando se conecta **la alimentación de reserva de red**  
**Posición del interruptor hacia la derecha**
- 5 Ajuste del tiempo de retardo de conmutación para pasar del funcionamiento acoplado a la red al funcionamiento de reserva de red
- 6 Ajuste del tiempo de retardo de retorno para pasar del funcionamiento conectado a la red al funcionamiento conectado a la red
- 7 Conmutación automática/manual
- 8 Conmutador entre la alimentación desde la red pública y el modo de reserva de red

## DISTANCIA DE MONTAJE Y DIMENSIONES

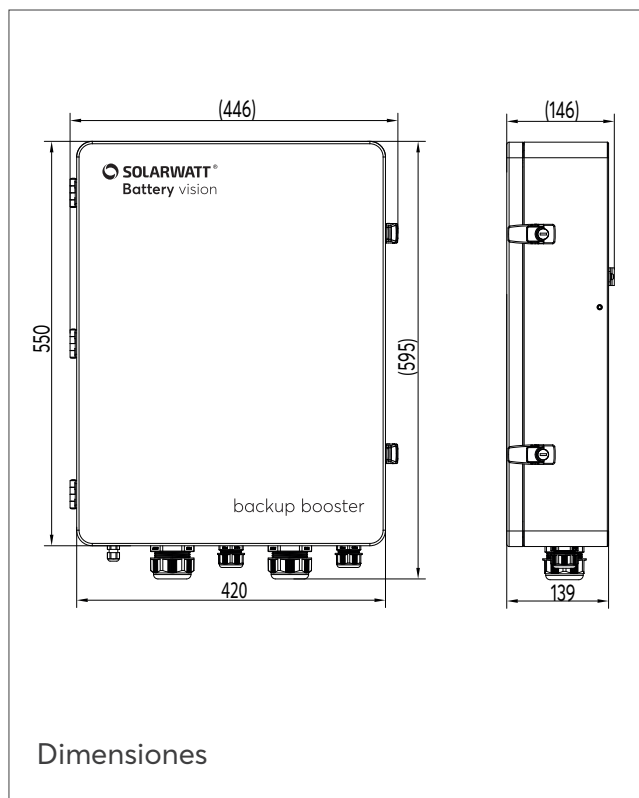
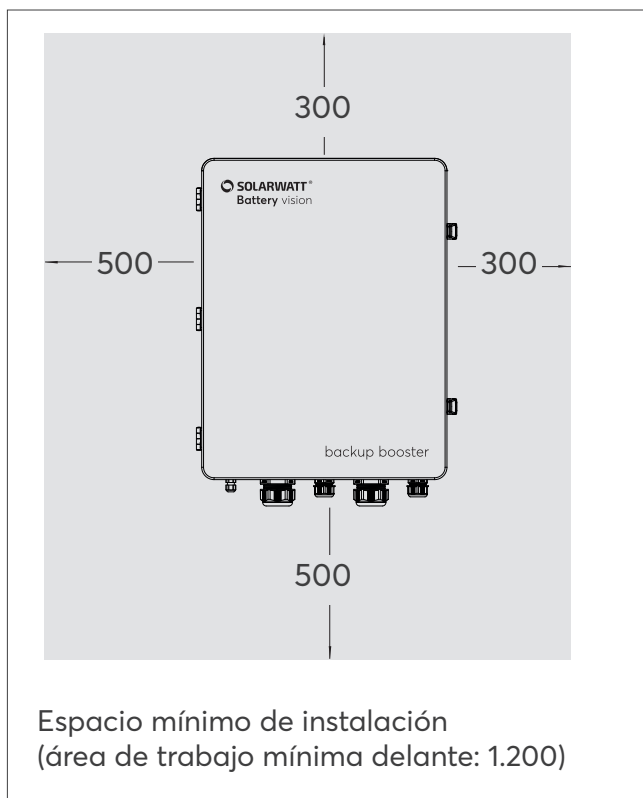

## MONTAJE

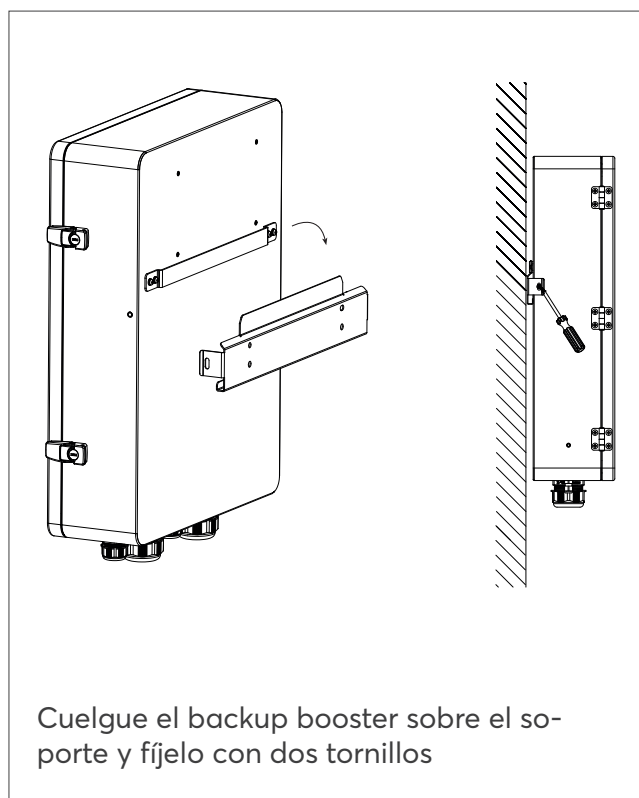
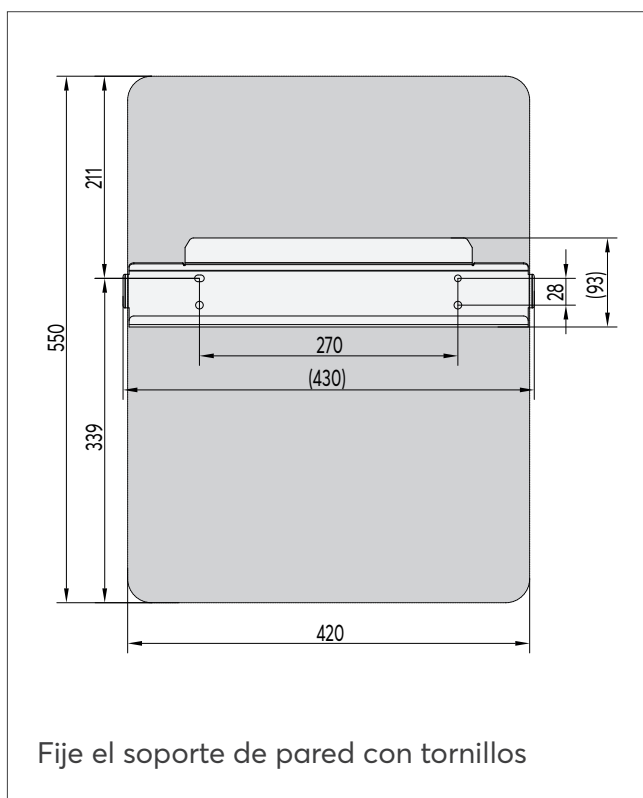

## INSTALACIÓN ENTRE DISTRIBUCIÓN DOMÉSTICA E INVERTER VISION

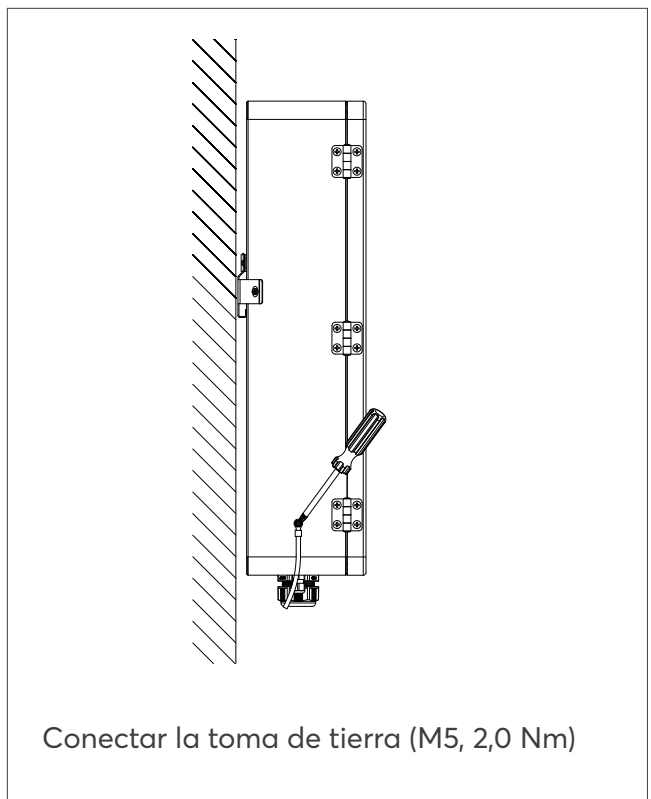
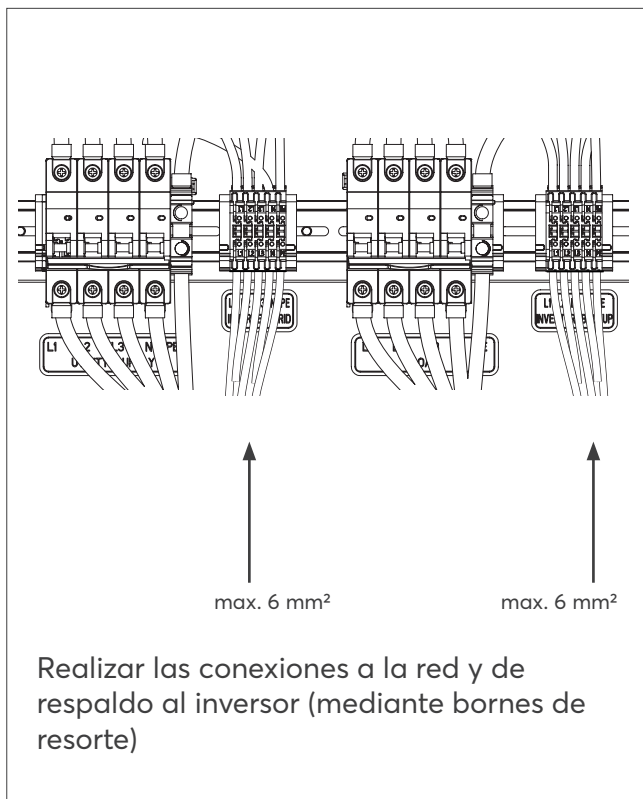
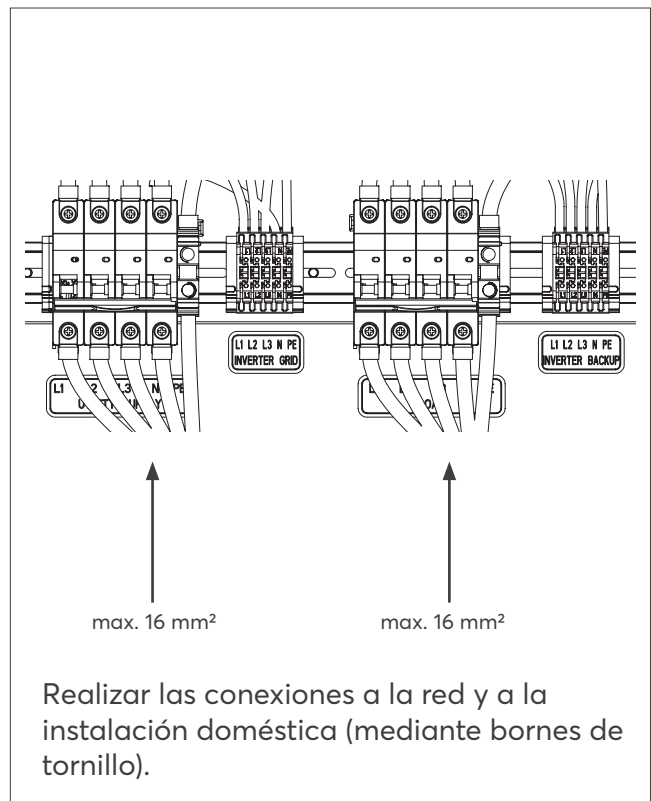
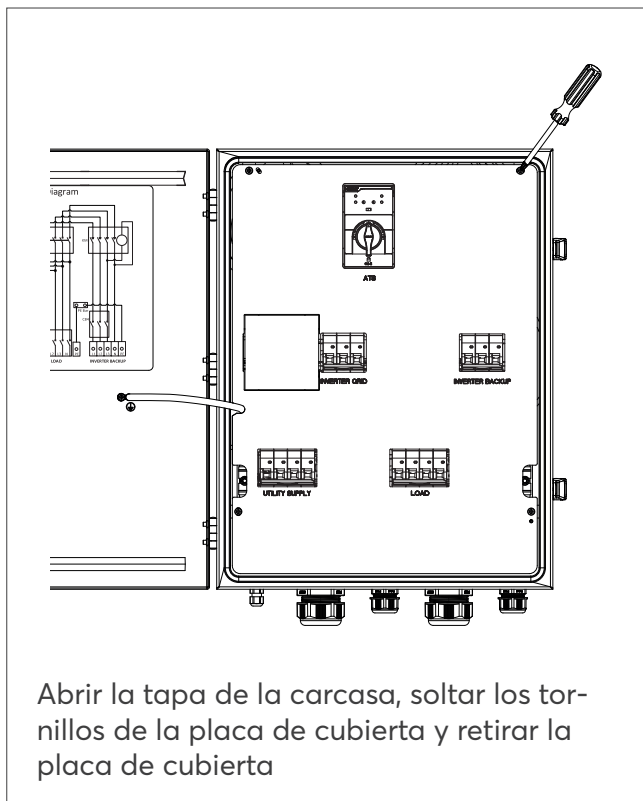

## **Do you have any questions? Please feel free to contact us.**

SOLARWATT Technologies Ltd.  
Shepperton Marina  
Felix Lane  
Shepperton TW17 8NS

+44-203-966-1952  
info.uk@solarwatt.com  
www.solarwatt.co.uk

## **Sie haben Fragen? Melden Sie sich gern bei uns**

SOLARWATT GmbH  
Maria-Reiche-Straße 2a  
01109 Dresden

+49-351-8895-555  
info@solarwatt.de  
www.solarwatt.de

## **Vous avez une question? N'hésitez pas à nous contacter.**

Solarwatt France  
15 Chemin du Saquin  
69130 Ecully

+33 (0) 4 69 85 17 70  
info.france@solarwatt.com  
solarwatt.fr

## **Se avete domande, non esitate a contattarci.**

Solarwatt Italia S.R.L. | Viale della  
Navigazione Interna n°52  
35129 Padova

info.italy@solarwatt.com  
solarwatt.it

## **Hebt u vragen? Neem gerust contact met ons op.**

Solarwatt BV  
Morsestraat 25  
4004 JP Tiel  
Nederland

+31 (0)344 767 002  
info.benelux@solarwatt.com  
solarwatt.nl/solarwatt.be